



New Jersey Department of Environmental Protection  
Division of Parks and Forestry  
State Park Service  
PO Box 420  
Mail Code 501-04  
Trenton, NJ 0862509420



# LIFEGUARD MANUAL

# STATE OPERATED LAKE BEACHES

May 2021

## TABLE OF CONTENTS

Foreword .....	3
Required Reading for all NJ State Lifeguards .....	4

### PERSONNEL

I. Responsibility .....	6
II. Training.....	8
III. Public Relations.....	11
IV. Personal Injury on Duty.....	12
V. Pathogen Exposure .....	13
VI. Information and Guidelines on Sun Protection .....	16

### REGULATIONS

I. Personnel Regulations .....	22
II. Uniform Regulations .....	24
III. Flotation Devices.....	25
IV. Beach/Bathing Regulations .....	27
V. Enforcement of Beach & Bathing Regulations .....	28
VI. Locker Room Regulations .....	28
VII. Disciplinary Policy .....	28

### EQUIPMENT AND REGULATIONS AND USES

I. General Equipment Regulations.....	29
II. Lifeguard Stands.....	29
III. Flags .....	30
IV. Kayaks .....	31
V. Rescue Boards.....	40
VI. Torpedo Buoys.....	50
VII. Backboard and Cervical Collars.....	42
VIII. Pocket Masks and Bag Valve Masks .....	57
IX. Beach Wheelchair .....	58
X. Mask, Fins, Snorkel .....	58
XI. Emergency Oxygen .....	60
XII. Automated External Defibrillator .....	60

## PROCEDURES

I.	Opening and Closing .....	62
II.	Communications .....	62
III.	Summoning Aid .....	65
IV.	Lost Children (Persons) .....	65
V.	Missing Children (Persons) .....	66
VI.	Water Search .....	66
VII.	Sighted Submersion .....	67
VIII.	Disturbances .....	72
IX.	Lightning .....	72
X.	Guarding .....	72
XI.	Rescue Procedure and Coverage .....	77
XII.	Removing Victims from Shallow Water to Beach .....	78
XIII.	Rescue Without Lifesaving Equipment .....	80

## **FOREWORD**

Lifeguards are responsible for the safety and wellbeing of the patrons who swim at their beach. To meet this responsibility a lifeguard needs:

1. Knowledge of rescue procedures coupled with swimming ability;
2. A thorough familiarity with lifeguard equipment and the techniques used in its application;
3. The confidence to analyze and act effectively to situations in the water and on the beach;
4. Trained eyes, so that visual control can be maintained over the area of responsibility;
5. To be physically fit, to meet the physical demands of the job.

A lifeguard also has the responsibility to help ensure that each patron has the optimum opportunity to enjoy the public facilities.

The information contained within this manual is the result of years of experience, research, and practical application. It is based on common sense, and the basic components of open-water lifeguarding. The rules pertaining to the public are based on providing recreation, health and safety for the majority. The personnel rules are not unreasonable and are for the protection of the public and lifeguards, while maintaining that degree of discipline necessary for the effective execution of a lifeguard's duties.

## **REQUIRED READING FOR ALL LIFEGUARDS**

1. Seasonal Employee Manual (State Park Service)
2. Lifeguard Manual (State Park Service)
3. American Safety and Health Institute Advanced First Aid for Non-EMS Personnel Student Handbook SKU: BKAF A-10N
4. American Health and Safety Institute Basic Life Support Student Handbook G2015 SKU: BKPRO-15N
5. American Health and Safety Institute Emergency Oxygen Student Handbook SKU: BKO2-10N
6. American Health and Safety Institute Bloodborne Pathogens Student Handbook SKU: BKBBP-15N
7. Lifeguarding Textbook (American Red Cross)  
ISBN 0-86536-181-9
8. Open Water Lifesaving USLA Manual Third edition  
1-323-58456-0

ASHI reading materials are available at [www.lifeforceusa.com](http://www.lifeforceusa.com)  
Mathew Giachetti <mat@lifeforceusainc.com>

# PERSONNEL

## I. RESPONSIBILITY

- A. Area Superintendent - The area Superintendent is responsible for all activities within the area and is the highest authority.
- B. Water Safety Supervisor - There is a Water Safety Supervisor in each region. This person assists the area Superintendents to ensure that all bathing areas are safely maintained and managed. As a member of the regional staff, this position is directly responsible to the Regional Superintendent.
- C. Head Lifeguard - The head lifeguard (Lt. or Sgt.) is responsible for maintaining a safe waterfront and transmitting orders, policies and procedures from the area Superintendent to the lifeguard staff. As administrative head of the lifeguard staff, the head lifeguard is responsible for:
1. Organizing, training, scheduling and supervising the lifeguards.
  2. Performing all lifeguard duties.
  3. Enforcing all regulations.
  4. Evaluating each lifeguard.
  5. Beach management.
  6. Maintaining required records.
  7. Daily inspection of beach area, First Aid Room and all facilities assigned to the lifeguards.
  8. Daily inspection of equipment and supplies.
  9. Reporting needed repairs or new/replacement equipment.
  10. The morale of the lifeguards.
  11. Reporting all safety and serious disciplinary problems to the area Superintendent
- D. Next-in-Command - In the absence of the head guard, the next-in-command performs those duties as outlined in C above. Normally the duties are:
1. Carries out orders issued by the head lifeguard.
  2. Responsible for the efficient performance and training of the lifeguards they are assigned to supervise.
  3. Perform all lifeguard duties.
- E. Lifeguard Duties

1. Pass all sections of lifeguard employment test prior to being hired, except in cases when they are hired as a lifeguard in training. **Stay alert and scan patrons in the bathing area.**
3. **Safeguard and regulate the conduct of patrons in the bathing area to prevent conditions that may lead to an accident.**
4. Enforce beach and bathing area regulations.
5. Performs rescues, CPR and rescue breathing when necessary.
6. Performs first aid at a level consistent with ASHI Advanced First Aid except in the case of a broken bone or dislocation. In the case of a broken bone or dislocation, the lifeguard will keep the victim stationary and comfortable until the ambulance arrives. The ambulance crew will splint and move the victim. **ONLY** if the situation requires the lifeguard to move the victim immediately, the fractures must be immobilized by splinting first.
7. Maintain and efficiently utilize lifeguard equipment.
8. Assist in maintaining a clean beach, employees' area and First Aid Room.
9. Assist in maintaining records.
10. Meet all training requirements.
11. Perform other duties as required or assigned. F.

#### Lifeguard First Aid Duties

1. Maintain first aid supplies in proper quantities and complete inventory every two weeks.
2. Check and refill first aid kits at the start of each day.
3. Maintain strict cleanliness in the first aid area.
4. Maintain first aid equipment in a clean, neat and workable condition.
5. Keep the head lifeguard informed of the status of first aid supplies and equipment.
6. Fill out and file a first aid report on first aid administered.
7. Review ASHI Advanced First Aid, BLS, Emergency Oxygen and Bloodborne Pathogens materials periodically throughout the season.
8. Must wear gloves when performing first aid or CPR. If the situation dictates, more protection (gowns and face shields) must be worn.

G. Unacceptable Lifeguard Conduct - Any let down in performance of duties that creates an unsafe



situation, will not be tolerated and may lead to dismissal.

## II. TRAINING

- A. First Aid/CPR - All lifeguards must have current American Red Cross Professional CPR/AED, Bloodborne Pathogen Training, Oxygen Administration, First Aid certificates and/or American Safety and Health Institute BLS, Advanced First Aid and Bloodborne Pathogens, certificates and be competent in the use of backboards and cervical collars. These skills will be reviewed throughout the season during in-service training.
- B. Physical - A lifeguard must meet physical training requirements each week.
1. The head lifeguard will be responsible in seeing that the physical training requirements and records are carried out. The head lifeguard may designate a physical training officer to administer physical training; however, the head lifeguard is ultimately responsible.
  2. Each full-time lifeguard must complete ten physical training requirements each week. Training requirements should be spread out over multiple days throughout the week. A Lifeguard officer, Superintendent or Water Safety Supervisor may assign physical training requirements as a part of the daily rotation.  
Substitution of one requirement for another is only permitted with prior permission of Water Safety Supervisor. On occasion, a guard may be exempted from physical training requirements. EXAMPLE: Lifeguard did not work all 5 days or bathing area is closed.
  3. Lifeguards working less than a 5-day week must complete a minimum of 2 training requirements per day.
  4. On occasion, a guard may have to do more than the minimum requirements in a week.
  5. Physical training may only be done during working hours when it does not compromise the safety of the bathers.
  6. Failure to complete required training will result in disciplinary action or dismissal.
  7. Supervisory lifeguards may allow guards to perform exercises individually or conduct structured sessions that include all guards.
  8. Physical Training.

### SWIM

Minimum is four 500-meter swims in at least 500-meter increments. When a lifeguard swims long distances from the bathing area or where boats may be present, extra safety precautions should be taken.

### PADDLE

Minimum is three 1,000-meter kayak/rescue board paddles in at least 1,000-meter increments.

### RUN

Minimum is three miles a week in at least one-mile increments.

- C. Rescue Procedures and Techniques - All rescue techniques and emergency procedures will be learned. As much time as necessary will be spent in acquiring and maintaining proficiency in these skills.
- D. Lifeguards are responsible for knowing all procedures, skills and regulations in the lifeguard manual and passing an examination on that material. Any lifeguard cheating on the manual test will be dismissed.
- E. Lifeguards are responsible for all material in the Seasonal Employee Manual.
- F. The following outlines the training to be received by new guards. This material must be reviewed by all returning lifeguards prior to carrying out lifeguard functions. All guards will review these skills and procedures throughout the season.

***ALL LIFEGUARDS ARE SUBJECT TO TESTING IN THE ABOVE SKILLS, AND THEIR PHYSICAL CONDITION, AT ANY TIME.***

## TRAINING PROGRAM

### A. Orientation

1. Objectives and Goals of Training Program
2. Using the lifeguard manual to achieve the objectives and goals of the training program
3. Chain-of-Command and Scope of Authority
4. Introduction to Equipment and Facilities
  - a. Torpedo Buoys (Rescue Cans, Torps)
  - b. Kayaks
  - c. First Aid and CPR/AED Equipment
  - d. Backboards and Related Equipment
  - e. Location of all Supplies and Equipment
  - f. Signs (Text, Location, Etc.)
5. Introduction to "Job of a Lifeguard"
  - a. Skills and performance required
  - b. Responsibility
  - c. Physical Fitness and In-Service Training
  - d. Preventative Lifeguarding
  - e. Public Relations
  - f. Enforcement of Beach & Bathing Area Regulations
  - g. Personnel Regulations
  - h. Disciplinary Policies
6. Communications
  - a. Hand and Whistle Signals
  - b. Telephone Procedures
  - c. Radio Procedures
  - d. Megaphone and Public Address
7. Environmental Hazards

### B. Lifeguarding Skills and Procedures

1. Scanning
2. Rescue and Emergency Coverage, Procedures
3. Rescues with Equipment

- a. Torpedo buoy
  - b. Kayak and rescue board
  - c. Conscious Victims
  - d. Unconscious Victims discuss in water rescue breathing with protection. (Ref. Open Water Lifesaving USLA Second Edition pg. 264.)
  - e. Multiple Victims
4. Rescues without Equipment
    - a. Approaches
    - b. Level Offs
    - c. Carries
    - d. Defenses
    - e. Releases and Escapes
  5. Mask, Fins, Snorkel
  6. Water Search
  7. Submersion
  8. Lost and Missing Persons
  9. Emergency Care and Transportation of Ill and Injured
    - a. ASHI BLS, Emergency Oxygen and Bloodborne Pathogen training, Or State or NREMT EMT with BLS
    - b. ASHI Advanced First Aid, Or State or NREMT EMT with BLS
    - c. Neck and back injuries in the water
    - d. Review pages 360-361 Open Water Lifeguarding USLA Manual 3rd Edition in the unlikely event of having to interact with a helicopter. Pay particular attention to static electricity when lowering a cable and landing.

C: Examinations:

1. Written Examinations on all phases
2. Practical Examinations on all phases
3. Timed Swims

III. PUBLIC RELATIONS

Lifeguards must remember that they work for a public service agency. Lifeguards are to be courteous at all times. Personal contact with a patron is preferable to yelling, whistle or megaphone, when possible. Lifeguards will enforce the rules for the area. Any difference of opinion will be referred to the head lifeguard, other supervisor, area office or State Park Police. Use of any offensive or obscene language by a lifeguard will not be tolerated. A lifeguard's conduct is a reflection upon the State of New Jersey. Lifeguards are expected to conduct themselves during duty hours and off

duty hours, in such a manner as to bring credit upon themselves, co-workers and the area in which they work.

IV. PERSONAL INJURY WHILE ON DUTY

Whenever the service of a doctor, dentist or hospital is needed because of an injury sustained while working, the area office must be notified prior to obtaining services when possible. The office will direct you to the nearest approved medical facility. If the facility is closed and urgent care is needed, proceed to the nearest hospital. Bills for doctors, the hospital, medication, etc. will be paid by the State of New Jersey in these cases. Check with the area office before paying with your own money or going to a doctor of your choice.

An employee first aid report must be filled out and signed by the immediate supervisor for any injury sustained on the job

## V. BLOODBORNE PATHOGEN EXPOSURE

Pathogens are disease-causing agents such as bacteria, viruses and other agents that present themselves in blood and other potentially infectious materials (OPIM). Viruses include: Human Immunodeficiency (HIV), Hepatitis B, Hepatitis C, and others. OPIM are defined as semen, vaginal secretion, cerebrospinal fluid, synovial fluid, plural fluids, pericardial fluid, peritoneal fluid, amniotic fluid, unfixed tissues or organs, and any body fluids visibly contaminated with blood.

When a lifeguard is performing first aid, CPR or other duties, they may be exposed to Bloodborne Pathogen or OPIM.

- A. Pathogen exposure is defined as any contact with blood or OPIM of another person that may enter the body through a needle stick, open cut, sore, or mucous membranes such as eyes or oral cavities. Contact with saliva, urine, feces, vomit, or sputum visibly contaminated with blood is considered an exposure.
  1. If exposure occurs:
    - a. Immediately wash effected area with soap and water. Antiseptic may be applied if available. The sooner the contamination is washed off, the less chance of infection. If splashed around mouth or nose, flush area with clean water. If eyes are affected flush for 20 minutes.
    - b. Immediately notify the area superintendent who must direct you to the nearest hospital or medical facility for treatment. The superintendent will fill out a RM-2 and contact appropriate state offices.
    - c. Go to approved medical facility immediately, explain exposure, and that this is a Workman's Compensation related injury. If approved facility is closed or approved facility information is not available go to the nearest hospital. Do not delay.
  2. When medical care has been completed for pathogen exposure the effected lifeguard must submit the following documentation from the medical provider to:  
Office of Occupational Health and Safety (OOHS)  
PO Box 416  
Trenton, NJ 08625  
Fax: 609-984-2488
    - a. That they been informed of any medical testing results
    - b. That they have been educated about medical conditions that can result from exposure to blood or OPIM.
- B. To prevent pathogen exposure a lifeguard:

1. Will be trained in Red Cross and/or ASHI Bloodborne Pathogen and Disease Prevention along with OOHS Bloodborne Exposure Control Plan for State Lifeguards and OSHA Bloodborne Pathogen Regulation 29 CFR 1910.1030. This training will be done yearly.
  - a. OSHA Bloodborne Pathogen standards are available online at: [www.state.nj.us/health/eoh/peoshweb/bbpslb.pdf](http://www.state.nj.us/health/eoh/peoshweb/bbpslb.pdf).
  - b. OOHS Complete Bloodborne Pathogen Exposure Control Plan for  
    - a. State Lifeguards is available at training and park office in addendum of Lifeguard Administration and Procedures Manual.
2. Must always use universal precautions whenever contact with body fluids is anticipated. Universal Precautions requires the employer and employee to assume that all human blood and body fluids are infectious for HIV, Hepatitis, or other Bloodborne Pathogen.
3. Must always use Personal Protective Equipment (PPE) including latex free disposable gloves and resuscitation protective device when performing first aid, CPR, or whenever contact with body fluids or blood is anticipated. Gowns, and eye protection are also available.
4. Dispose of PPE after each use and each victim. The same PPE should not be used on multiple victims.
5. Hands should be washed if possible before providing care. Hands must be washed immediately following removal of gloves. If soap and water is not available other washing methods such as alcohol-based sanitizers must be used. Sanitizers are only a temporary solution. Soap and water should be used as soon as possible. There shall be no eating, drinking, smoking, handling contact lenses, or applying cosmetics until hands are washed with soap and water.

C. Contaminated (Infected) materials, clothing, or regulated waste must be handled as followed:

1. Uniforms with any blood or body fluids from another person on them must be discarded. Do not attempt to wash or clean.
2. Non-disposable contaminated materials (backboard, floor, etc.) must be cleaned, and then sanitized with diluted bleach (12 ounces bleach to 1 gallon of water, about 10%). The bleach solution should stand for at least 10 minutes then be wiped dry.
3. To dispose of any materials completely saturated with blood or body fluids (Saturated means if the material was squeezed fluid would escape), follow the procedures below:

- a. Give saturated material to ambulance. They have a bag for this material. The ambulance disposes of material at the hospital.
  - b. If an ambulance does not respond to first aid and blood saturated materials must be disposed of. The State Park Police must be contacted for disposal (Ambulance is first option).
  - c. Unsaturated materials (like some blood on gauze, band-aid, etc.) is thrown in regular trash.
4. Do not touch syringes or any medical waste found on beach or bathing complex. State Park Police must be notified for disposal. Keep public away from material. Park Police must notify NJ DEP Communication Center of incident.

D. Hepatitis B Immunization – All Lifeguards will be offered a free Hepatitis B Vaccination when hired. This immunization is not mandatory.

- 1. All lifeguards must complete the Hepatitis Immunization Form, every year to indicate acceptance, refusal, or already received immunization.
- 2. Lifeguards who have already received immunization and want to be tested for effectiveness of previous immunization may request a titer on the Hepatitis immunization form.
- 3. The vaccine is prepared from recombinant yeast cultures rather than human blood and as a result there is no risk of contracting the Hepatitis B Virus from the vaccine.
- 4. The park superintendent will notify you of the date and time you are to receive injection 1 and 2 of the immunization series. This is considered a work assignment and you will be provided transportation.
- 5. Injection 3 is 5 months after injection 2. The 3<sup>rd</sup> injection is scheduled in December or January. At this time the lifeguard is no longer an employee of the state of New Jersey. As a courtesy the third injection is free of charge. However, the lifeguard is responsible to call OOHS at 609-292-1408 to schedule injection 3. The lifeguard is responsible to supply their own transportation for injection 3. Lifeguards may elect to have their own physician administer the 3<sup>rd</sup> injection. If that is the case, documentation is required and must be sent to: OOHS, PO Box 416, Trenton, NJ 08625-0416

If a lifeguard declines immunization when hired, they may request vaccination at a later date.



VI. INFORMATION AND GUIDELINES ON SUN PROTECTION - EACH LIFEGUARD WILL BE ISSUED SUNSCREEN AND POLARIZED SUNGLASSES WITH UV PROTECTION

- A. The following information is reprinted from the pamphlet "The Sun and Your Skin" with the permission of the American Academy of Dermatology, P.O. Box 4014, Schaumburg, Illinois 60168-4014.

**"The Sun and Your Skin"**

Soaking up the sun's rays used to be considered healthy, before we learned about the dangers of ultraviolet rays.

Sunlight can be used to treat some skin diseases, but we all need to avoid overexposure to the sun. Too much sun can cause wrinkles, freckles, skin texture changes, dilated blood vessels and skin cancers. It may also cause other problems.

**The Sun's Rays**

The sun produces both visible and invisible rays. The invisible rays, known as ultraviolet-A (UVA) and ultraviolet-B (UVB), cause most of the problems. Both cause suntan, sunburn and sun damage. There is no "safe" UV light.

Harmful UV rays are more intense in the summer, at higher altitudes and closer to the equator. For example, Florida receives 150% more UV than Maine. The sun's harmful effects are also increased by wind, reflections from water, sand and snow. Even on cloudy days UV radiation reaches the earth.

**Protection from the Sun**

Using sun protection will help prevent skin damage and reduce the risk of cancer. The American Academy of Dermatology recommends that you avoid deliberate sunbathing, wear a wide-brimmed hat, sunglasses and protective clothing and if you must be in the sun, use a sunscreen with a sun protection factor (SPF) of at least 15, even on cloudy days.

Sunscreens work by absorbing, reflecting or scattering the sun's rays on the skin. They are available in many forms, including ointments, creams, gels, lotions and wax sticks. All are labeled with SPF numbers. The higher the SPF, the greater the protection from sunburn, caused mostly by UVB rays. Some sunscreens, called "broad spectrum," block out both UVA and UVB rays. These do a better job of protecting skin from other effects of the sun, including rashes. Sunscreens are not perfect, however. Sun protection should always start with avoiding peak sun hours and dressing sensibly.

Sunscreens should be applied about 20 minutes before going outdoors. Even water-resistant sunscreens should be reapplied often, about every two hours or after swimming or strenuous activities.

Beach umbrellas and other kinds of shade are a good idea, but they do not provide full protection because UV rays can still bounce off sand, water and porch decks. Remember, UV rays are invisible.

Most clothing absorbs or reflects UV rays, but white fabric like loose-knit cotton and wet clothes that cling to your skin do not offer much protection. The tighter the weave, the more sun protection it will offer.

## **Effects of the Sun**

**Sunburn** - Your chances of developing sunburn are greatest between 10 am and 4 pm, when the sun's rays are strongest. It's easier to burn on a hot day, because the heat increases the effects of UV rays.

Sun protection is also important in the winter. Snow reflects up to 80 percent of the sun's rays, causing sunburn and damage to uncovered skin. Winter sports in the mountains increase the risk of sunburn because there is less atmosphere to block the sun's rays.

If skin is exposed to sunlight too long, redness may develop and increase for up to 24 hours. A severe sunburn causes skin tenderness, pain, swelling and blistering. Additional symptoms like fever, chills, upset stomach and confusion indicate a serious sunburn and require immediate medical attention. If you develop a severe sunburn or begin to develop a fever, your dermatologist may suggest medicine to reduce swelling, pain and prevent infection.

Unfortunately, there is no quick cure for minor sunburn. Wet compresses, tub baths and soothing lotions may provide some relief.

**Tanning** - A tan is often mistaken as a sign of good health. Dermatologists know better. A suntan is actually the result of skin injury. Tanning occurs when UV rays enter the skin and it protects itself by producing more pigment or melanin. Indoor tanning is just as bad for your skin as sunlight. Most tanning salons use ultraviolet-A bulbs and studies have shown that UVA rays go deeper into the skin and contribute to premature wrinkling and skin cancer.

**Aging** - People who work outdoors or sunbathe without sun protection can develop tough, leathery skin, making them look older than they are. The sun can also cause large freckles called "age spots" and scaly growths (actinic keratoses) that may develop into skin cancer. These skin changes are caused by years of sun exposure. Protecting children from the sun is especially important, since most of our lifetime exposure occurs before the age of 20.

**Skin Cancer** - More than 90 percent of all skin cancers occur on sun-exposed skin. The face, neck, ears, forearms and hands are the most common places it appears.

The three most common types of skin cancer are basal cell carcinoma, squamous cell carcinoma and melanoma.

Basal cell carcinoma usually develops on the face, ears, lips and around the mouth of fair-skinned individuals. It can start as a red patch or shiny bump that is pink, red or white. It may be crusty or have an open sore that does not heal or heals only temporarily. This type of cancer can be cured easily if treated early.

Squamous cell carcinoma usually appears as a scaly patch or raised, warty growth. It also has a high cure rate when found and treated early. In rare cases, if not treated, it can be deadly.

Melanoma is the most dangerous form of skin cancer. It usually looks like a dark brown or black mole-like patch with irregular edges. Sometimes it is multicolored with shades of red, blue or white. This type of skin cancer can occur anywhere on the body and when found early, can be cured. If ignored, it spreads throughout the body and can be fatal.

**Allergic Reactions** - Some people develop allergic reactions to the sun. These reactions may show up after only a short time in the sun. Bumps, hives, blisters or red blotches are the most common symptoms of a sun allergy. Sometimes these reactions are due to cosmetics, perfumes, plants, topical medications or sun preparations. Certain drugs, including birth control pills, and blood pressure, arthritis and depression medications can cause a skin rash with sun exposure. If this occurs, a dermatologist can help.

**Diseases** - Some diseases can be made worse by the sun, including cold sores, chicken pox and a number of less common disorders such as lupus erythematosus, UV rays also can cause cataracts, a gradual clouding of the lens of the eye.

### **Tips for Sun Protection**

1. Use a broad-spectrum sunscreen with an SPF of at least 15 on all exposed skin, including the lips, even on cloudy days.
2. Reapply sunscreen frequently.
3. Wear a broad-brimmed hat and sunglasses.
4. Sit in the shade whenever possible.
5. Wear protective, tightly woven clothing.
6. Plan outdoor activities early or late in the day to avoid peak sunlight hours between 10 am and 4 pm.

Everyone should be able to enjoy sunny days. By using a little common sense, as well as the guidelines developed by the American Academy of Dermatology, you can safely work and play outdoors without worrying too much about skin cancer or wrinkles.

- B. The following information on protecting your eyes is from the pamphlet "Sunglasses Are More Than Shades". It is reprinted with permission of the American Optometric Association, 243 North Lindbergh Blvd. St. Louis, Missouri 63141. You are probably aware of the danger posed by UV radiation to your skin but you may not realize that exposure to UV radiation can harm your eyes and affect your vision as well.

### **"Sunglasses Are More Than Shades"**

#### **Effects of Ultraviolet Radiation**

In addition to visible light, the sun gives off two other types of radiation, infrared (IR) and ultraviolet (UV). The effects of infrared radiation are less well known but are thought to be harmless to the eyes. UV radiation is divided into UV-A, UV-B and UV-C. UV-C is absorbed by the ozone layer and does not present any threat (manmade sources of UV-C, like electric

welding arcs are very harmful to the eyes if you do not wear proper protection).

Mounting scientific evidence shows long-term exposure to both UV-A and UV-B can contribute to the development of cataracts; retinal problems; benign growths on the eye's surface; cancer of the eyelids and skin around the eyes; and photo keratitis, a temporary but painful sunburn of the eye's surface (sometimes called snow blindness or welder's flash).

### **Glare Protection**

Disability glare is associated with the sun's brightness and it interferes with your comfortable vision and your ability to see clearly. It causes you to squint and your eyes to water. Disability glare can occur on both sunny or cloudy days and sunglasses that screen out 75 to 90 percent of available light are effective in reducing the brightness and the effects of disability glare.

When the sun's light bounces off snow, water, sand or highway pavement, reflected glare occurs. Polarizing sunglasses are more effective at eliminating reflected glare than ordinary sunglasses.

Reducing glare makes driving as well as outdoor recreational and occupational activities safer and more comfortable and productive.

### **Choosing the Right Sunglasses**

There are many options that you can consider when purchasing sunglasses. Here are some:

- \* Polarizing lenses effectively reduce reflected glare, sunlight that bounces off smooth surfaces such as water or pavement. They are particularly useful for driving, boating and lifeguarding.
- \* Photochromic lenses darken or lighten with the amount of light available.
- \* Mirror coatings reflect rather than absorb light and are primarily for wear under intense glare from snow or water.

No matter what sunglass styles or options you choose, you should insist that your sunglasses:

- \* block out 99-100 percent of both UV-A and UV-B radiation;
- \* screen out 75-90 percent of visible light (fashion tinted lenses usually do not meet this level);
- \* are perfectly matched in color and are free of distortion and imperfection;
- \* have lenses that are gray, green or brown (gray is recommended).

If you wear your sunglasses for eye hazardous sports or work, you should choose polycarbonate lenses. These lenses provide the greatest available impact protection.

Wrap-around sunglasses, which are shaped to keep light from shining around the frames can be worth considering, particularly if you spend a lot of time outdoors in bright sunlight.

Wearing a wide brimmed hat provides additional protection from UV radiation.

### **Purchasing Sunglasses Can Be Complicated**

It can be difficult to be certain the sunglasses you purchase are right for you because there are no federal sunglass regulations regarding UV radiation and visible light transmission levels, and lens quality. And, don't be confused. Price is not necessarily a gauge of lens quality or UV blockage.

Here are some ways to judge non-prescription sunglass quality:

- \* Check lenses to be sure the tint is uniform, not darker in one area than another (except gradient density lenses).
- \* Hold glasses at arm's length and look through them at a straight object. Slowly move the lens across the object. If the edge of the object distorts, sways, curves or moves, the lens has imperfections.
- \* To be sure the lenses block enough light, try them on in front of a mirror. If you can see your eyes clearly through the lenses, they probably are not dark enough for glare reduction and comfort. This test does not apply to photochromic lenses.
- \* Ask your optometrist to help you check your lenses' UV protection capabilities, to suggest which options are most appropriate for your needs and to help you decide which sunglasses are best for you.

# **REGULATIONS**

## I. PERSONNEL REGULATIONS

- A. No person other than a member of the lifeguard staff will assume the duties of a lifeguard at any time.
- B. A lifeguard must be on duty on a stand at all times when there are bathers or potential bathers in the beach area, during assigned guarding hours.
- C. Lifeguards are to remain at their assigned positions at all times until properly relieved, unless an emergency occurs.
- D. Lifeguards are not to sit anywhere other than on the assigned stand when on stand duty. This includes the beach area adjacent to the stand.
- E. Lifeguards must satisfactorily complete all training requirements.
- F. A lifeguard is not to accept, in any form, remuneration for lifeguard services rendered while in the employ of the State of New Jersey, except a paycheck.
- G. Lifeguards will perform all duties and responsibilities promptly.
- H. Lifeguards are to enforce the beach/bathing rules at all times with impartiality.
- I. Lifeguards are to be courteous at all times.
- J. Lifeguards have complete authority and responsibility for the bathing area assigned to them. They are not to take orders or directions from anyone except their beach supervisor, or other supervisor, who has been given authority to do so by the chain-of-command within the area, region, or state.
- K. A lifeguard is not to strike another person except in defense of his/her own person.
- L. Lifeguards are to report all incidents and first aid cases of a serious nature to the area Superintendent through the chain-of-command.
- M. While on duty a lifeguard may not be under the influence of or consume any form of alcoholic beverage or controlled substance. A lifeguard taking medication must get a written statement from his/her physician stating that they can perform all duties. Violations may result in suspension or dismissal.
- N1. Lifeguard's personal appearance must conform to standards as established in the State Park Service Seasonal Employee Manual, this manual, and as established by the area Superintendent.
- N2. Jewelry or objectionable attire that can pose a safety issue shall not be worn. Medical alert medals and wrist watches are not considered jewelry. A medical alert medal must be securely fastened. Wrist watches must be securely fastened. This regulation is for your safety and the safety of the public.
- O. Lifeguards are not to engage in conversation with patrons that may be construed as detrimental

to any individual, or to the system in which they are employed. Complaints or grievances should be addressed to supervisors through the chain-of-command.



- P. Lifeguards are not to make state park related statements to any individual or the news media without the consent of the area Superintendent. Lifeguards will not make any verbal, written, media or internet statements regarding any incident they may have observed or been involved in while on duty unless they have the permission of the Superintendent.
- Q. No person other than a lifeguard may sit on a lifeguard stand at any time, except in the case of a lost child.
- R. Lifeguards will not further social relationships while on duty.
- S. Lifeguards are not to cease bathing operations without permission from the area Superintendent through the chain of command except in an emergency. If such an emergency occurs, the area Superintendent will be notified as soon as possible.
- T1. Lifeguards are not to render any medical treatment or advice other than ASHI Advanced First Aid or BLS unless certified by the NJ Department of Health and Senior Services as an EMT. An EMT may carry out any care specified by their certification. An EMT must submit a copy of EMT certification for his/her personnel file.
- T2. Lifeguards not currently certified in CPR or First Aid should not perform these functions.
- U. Lifeguards will not allow any beach patron to treat a victim under his or her care. The victim will only be turned over to the first aid squad or paramedics upon their arrival.
- V. Lifeguards are not to dispense any first aid supplies other than in the performance of their duty.
- W. Lifeguards are not to eat, loiter, or congregate in the first aid area. Lifeguards are not permitted to smoke while on active duty or in public view.
- X. All lifeguards must be available in the event of any emergency as determined by the head lifeguard or the area Superintendent. During breaks other than lunch, a lifeguard must remain on alert in the vicinity of the beach area.
- Y. Lifeguards are expected to treat their co-workers and supervisors with respect and exercise every consideration in their relationships to ensure maximum area efficiency. All area personnel are expected to work together as a team to achieve this end result.
- Z. Lifeguards must adhere to their weekly work schedules unless they have sufficient cause such as illness, death in the immediate family, etc. The area supervisor must be notified of any absence at least 30 minutes prior to your scheduled starting time.
- AA. Lifeguards will enter unfamiliar water outside bathing area or any shallow water, cautiously feet first.
- AB. Lifeguards are advised to wear polarized sunglasses with UV protection for their personal protection except in low light conditions. Approved sunglasses for wear are provided by the State Park Service.

- AC. A lifeguard may request professional counseling if stressed by an incident. The Park Superintendent is the contact person.
- AD. The use of personal electronic devices, such as cell phones, is not permitted during working hours; unless required for official communication or during unpaid lunch breaks. The park will supply necessary communication devices.
- AE. A lifeguard will practice social distancing to take precautions against the spread of COVID.
- AF. A lifeguard will wear a mask at all times while in buildings and will take necessary precautions against the spread of COVID.

## II. UNIFORM REGULATIONS

Adhering to the following uniform regulations is a condition of employment. Failure to comply with the following regulations will be considered insubordination and subject to disciplinary action.

- A. Only State issued uniforms and approved uniform items may be worn when working as a lifeguard. All required lifeguard uniform components will be issued by the State Park Service as follows:
  1. Male swimsuit (RED) with Division logo.
  2. Female swimsuit (RED) with Division logo.
  3. T-Shirt (WHITE) with Division logo.
  4. Hat with Division logo.
  5. Rain Parka (RED) with the "DIVISION LOGO". This uniform component is an "area" issue and not an "individual" issue.
- B. The only clothing a lifeguard may wear other than the State issued uniform is a State Park Service approved women's two-piece swimsuit, a sweatshirt, sweatpants, approved sun protective clothing and a wide brim hat. The only swimsuits, sweatshirts, sweatpants and wide brim hat permitted must be purchased from the NJ State Park Service or State Park Service approved vendor. A lifeguard may use their own unmarked light gray sweat suit with NJ State Park Service patches sewn on the left leg and left breast area. The approved sun protective clothing is a white long sleeve shirt and white pants. A NJ State Park Service patch must be sewn onto sun protective clothing. A list of manufacturers of sun protective clothing may be obtained from your Superintendent or Water Safety Supervisor. NJ State Park Service patches are requested from your Water Safety Supervisor.
- C. The uniform items shall only be worn while on duty performing lifeguard functions or traveling to and from work.
- D. It is suggested that lifeguards wear the provided uniform shirt when not in the water. In water activities include training exercises, deep/shallow water

patrols, deep water/kayak water patrols, missing person searches and rescues.

- E. Uniform items will not be changed, altered, or modified in any way.
- F. All uniform items are to be clean and in good repair at all times.
- G. All uniform items are not to be traded or loaned.
- H. All uniform items are not to be worn by anyone other than lifeguard personnel.
- I. Any loss or damage to uniform items is to be reported immediately through the chain-of-command.
- J. Any necessary uniform exchanges or replacements are to be requested through the chain-of-command.
- K. Any damage or loss of State provided uniform items or other lifeguard equipment that results from negligence of any lifeguard will result in monetary reimbursement to the State by involved employees
- L. Whistles and lanyards will be worn around the neck at all times when on duty.
- M. No sneakers or shoes other than water shoes may be worn while on lifeguard stand.
- N. When off the lifeguard stand shoes or sandals should be worn whenever possible (breaks, bathroom, etc.). Foot injuries are the #1 lifeguard injury.

### III. FLOTATION DEVICES

The prohibition of flotation devices on state operated beaches is a policy made to ensure water safety. A large number of drownings each year in the United States may be attributed, either directly or indirectly, to the use of flotation devices. The only flotation devices allowed are Coast Guard approved lifejackets and devices worn properly. If a disabled patron must use an unapproved flotation device, this individual must be referred to the Superintendent. The Superintendent may approve an unapproved flotation device for a disabled person using the procedure found in Chapter 10 of the Lifeguard Administrative and Procedures Manual. The following are some of the factors considered in establishing the policy prohibiting the use of flotation devices:

- A. They offer a bather a false sense of security and often prompt non-swimmers to venture into water over their heads.
- B. If a strong wind or current is moving away from the beach, bathers, and especially small children, are likely to drift out, because use of arms for propulsion is difficult with a flotation device on.
- C. The flotation device may be blown out of reach of the bather if it is momentarily released or if the bather should fall off or out of the device.
- D. All inflated objects are subject to leaks and punctures.

- E. If a bather is knocked off his/her feet, any device positioned around the waist may prevent the bather from regaining his/her footing.
- F. Children with floatation devices are usually not supervised as closely by their parents.
- G. When a flotation device is Coast Guard approved it has been tested and we know it is reliable. There is no assurance of reliability for a non-Coast Guard approved device.
- H. A lifeguard cannot evaluate the swimming ability of a bather with a flotation device.

#### IV. BEACH AND BATHING AREA REGULATIONS

Within the confines of the beach and the bathing area there shall be no:

- A. Ball or frisbee playing (in other than designated areas).
- B. Fires.
- C. Consumption of alcoholic beverages.
- D. Kite flying.
- E. Nudity.
  - E.1. Breast feeding is permitted; breastfeeding is exempt from public indecency laws
- F. Dogs, other than service animals
- G. Use of snorkels by other than lifeguard personnel.
- H. "Horseplay" or conduct that may result in injury.
- I. Scuba diving unless approved by the area office.
- J. Loud radios, or other electronic devices.
- K. Bathing or swimming outside of the bathing area.
- L. Fishing when the bathing area is open to public recreational bathing.
- M. Glass Containers.
- N. Spitting.
- O. Bathing by people under the influence of drugs or alcohol.
- P. Profane language.
- Q. Children in diapers, in the water, unless diapers are covered by plastic pants with snug

fitting elastic waist and leg bands.

- R. Feeding of geese, seagulls, or other birds.
- S. Boats within 200 feet of bathing area. The area that boats are excluded is marked with buoys.
- T. Metal detector use on beach and in bathing area between 10 am and 5:30 pm. For use of metal detector at other times, refer patron to area office.
- U. Remaining on the beach during electrical storms or beach closures.

V. ENFORCEMENT OF BEACH AND BATHING AREA REGULATIONS

- A. The enforcement of all rules and regulations within the designated bathing area is the responsibility of the assigned lifeguards.
- B. The assistance of State Park Police, or the area Superintendent, is to be requested if a condition arises that is beyond the ability of a lifeguard to resolve, i.e. drunk and disorderly behavior, weapons in the beach area complex, etc.
- C. A lifeguard will not jeopardize the safety of bathers by leaving the bathing area to tend to patrons breaking rules outside of the bathing area.

VI. LOCKER ROOM REGULATIONS

- A. Locker Room may be used by employees during working hours.
- B. Locker Room will be swept clean each day of sand and litter.
- C. All waste cans shall be emptied and relined with a clean waste bag daily.
- D. Facilities will be secured each day after closing.

VII. DISCIPLINARY POLICY

Failure of a lifeguard to carry out any personnel, uniform or beach regulations will result in disciplinary action or dismissal.

# **EQUIPMENT REGULATIONS AND USES**

## I. GENERAL EQUIPMENT REGULATIONS

All equipment is the property of the State of New Jersey.

### A. Use

State owned equipment will only be used in the prescribed manner. It will not be used in any manner that will create a hazard to any person. Unauthorized persons will not be allowed to use lifeguard equipment.

### B. Inventory

An inventory of all state-owned lifeguard and lifeguard related equipment is to be submitted by the head lifeguard to the area Superintendent before opening day and again on or before October 10th of each year. All inventories are to be listed on designated inventory sheets. In addition to inventories for the Superintendent, inventories will be regularly for lifeguard records. Any deficiencies discovered should be addressed.

### C. Damage or Loss

All equipment is to be inspected daily. All damage is to be reported to the area Superintendent immediately. Equipment is not to be loaned, given away, destroyed, or otherwise dispensed with, regardless of condition without permission of Superintendent. Any non-usable piece of equipment is to be reported to the regional water safety supervisor in addition to the Superintendent.

### D. Acquisition

Equipment is not to be purchased by any individual for, or on behalf of, the State of New Jersey without the permission of the area Superintendent. A piece of equipment not presently available, that will improve efficiency, may be recommended for purchase to the head lifeguard.

### E. Repair

Any repairs of lifeguard equipment which cannot be accomplished within the area will be reported to the area Superintendent. Any repairs requiring the expenditure of money will also be reported to the area Superintendent.

## II. LIFEGUARD STANDS

### Regulations

- A. Stands should always be as close to the water's edge as is practical. Stands will not be more than 30 feet from water.
- B. Each stand should not cover more than 200 feet. 100 Feet on each side.
- C. Every stand should have a minimum of one torpedo buoy per lifeguard.

- D. Kayaks and rescue boards should be distributed to stands so the equipment is balanced over the entire bathing area.
- E. Each stand should have a First Aid Kit containing bandages, dressings, band-aids, gloves, pocket mask, ice packs and BVMs. Additional bag valve masks (adult and child) will be kept with the oxygen in the first aid rooms.
- F. Articles of clothing or personal effects should never be hung or draped over the back of stands.
- G. Patrons are not to be allowed to loiter in front of the stands.
- H. Stands are not to be opened or closed without permission of the head guard.
- I. Lifeguard stands will be staffed when any patron(s) are in the water or on the beach during normal operating hours.
- J. Lifeguard stands shall always remain in an upright position unless necessary to move or lay down for storm or hazardous weather preparation.
- K. Tamper proof signs shall be posted on the back of each Lifeguard stand to indicate that swimming is not permitted when Lifeguards are not on duty. For example: "Swimming hours 10:00am to 6:00pm when Lifeguards are on duty", or "No swimming when Lifeguards are not on duty.
- L. Stands should be examined for damage at the beginning and end of each day. All damage should be reported immediately through the chain-of-command.
- M. Area in front of stand should be clear of public's blankets and umbrellas. If an umbrella is in your line of sight have it moved.

### III. FLAGS

Flags are used to mark the ends of the bathing area and danger areas in some parks. Red flags mark no swimming and danger areas.

#### Regulations

- A. Flags are to be used only in prescribed manner.
- B. Flags and poles are to be kept in an excellent state of repair. Tattered flags should be reported for replacement immediately.
- C. The placement of the flags on the beach will be determined each morning by the head guard.



- D. Flags are not to be moved at any time during the day without the permission of the head lifeguard.

#### IV. KAYAKS

Lifeguard kayaks are open-top kayaks that are twelve (12) feet long and weigh about forty-five pounds. Kayaks are a highly efficient method of patrolling and bringing victims to shore. One or two victims can be put on top of the kayak. The kayak will support numerous victims hanging from the side of the kayak.

##### A. Regulations

1. Kayaks not in use are to be kept next to the lifeguard stand or in designated location for effective deployment.
2. Kayaks should be distributed evenly on the beach.
3. When using a kayak, dragging it along the beach should be kept to a minimum.
4. All kayaks will be equipped with an asymmetric paddle, line clip attached to center of paddle, backrest, torpedo buoy and PFD.
5. Water should be emptied through the drainage hole at least once a day.
6. Any damage to the kayak or its equipment should be reported through the chain-of-command immediately. This way repairs can be made as quickly as possible.
7. Be careful not to run over anyone with kayak.

##### B. Use of Kayak

1. When to use:
  - a. For deepwater patrol
  - b. Rescues in which long distances must be covered
  - c. Rescues with multiple victims
  - d. Rescues where large amounts of debris or weeds are present
  - e. To assist capsized or disabled boats provided the bathing area is sufficiently protected
2. When not advisable to use:
  - a. Within crowded areas
  - b. On rescues that require the kayaks to be carried long distances

### C. Paddling the Kayak(P-1K)



#### **P K**

1. Grip the paddle from above and a little wider than shoulder width.
2. The center of the paddle should be at the height of your neck.
3. Sit up straight.
4. Keep your shoulders square. Your shoulders should not be swinging back and forth or dipping down while paddling.
5. Grip the paddle tightly with your dominant hand. The paddle should rotate in your non-dominant hand. Your non-dominant hand only grips the paddle tight when taking a stroke on that side.
6. The power of your stroke is 60%

pushand40%pull.

### D. Turning the Kayak

1. Backstroke on the side you want to turn to followed by a front stroke on the opposite side if needed. Continue this pattern until the desired direction is achieved.

### E. Stopping the Kayak

1. Back paddle, alternating sides.
2. Turn stroke.
3. Bail out and hold onto

thekayak

F. Getting to the Victim

1. Entering the Water

- a. Drag kayak into water using rope handle on the bow. Watch out for patrons.

(P-2K).



**P-2K**

- b. Rescuer pulls kayak to his/her side while putting one hand on opposite side of the kayak for stability. Now just sit in kayak and begin paddling (P-3K).

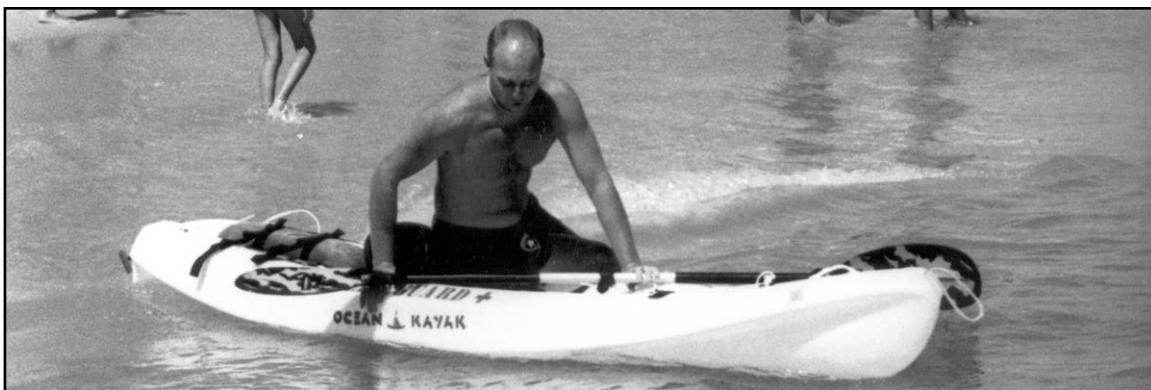

**P-3K**

2. Paddling to Victim

- a. Keep eye contact with the victim
- b. Follow previous directions for paddling kayaks

G. Making the Rescue

1. Tired Swimmer Rescue

- a. Rescuer approaches so the victim is on the side of the kayak. Clip the paddle to the kayak. Rescuer will straddle kayak for more stability and move forward to assist the victim (P-4K)



**P-4K**

- b. Instruct victim to grab side of kayak then pull victim's arms across front of kayak (P-5K).



**P-5K**

- c. Ask victim to kick his/her legs while pulling victim's chest and shoulders into kayak (P-6K).



**P-6K**

- d. Swing victim's legs into kayak (P-7K).



**P-7K**

- e. Rescuer moves behind normal paddling position for better balance and paddles victim to shore (P-8K).



**P-8K**

- f. An alternative to bringing a tired swimmer aboard the kayak is to have the victim hang from the bow of the kayak while paddling the victim to safety (P-9K). It is more difficult to paddle with the victim hanging from the kayak but it may be more practical for a short distance or a large victim.



**P-9K**

2. Unconscious Victim

- a. Approach so the victim is on the side of the kayak and clip the paddle onto victim side of kayak.
- b. Capsize the kayak in the direction of the victim as you leave the kayak to rescue the victim (P-10K).



**P-10K**

- c. Victim is brought to front section of kayak using non-equipment rescue techniques (P-11K).



**P-11K**

- d. Rescuer climbs on top of kayak while holding the victim's arms (P-12K).

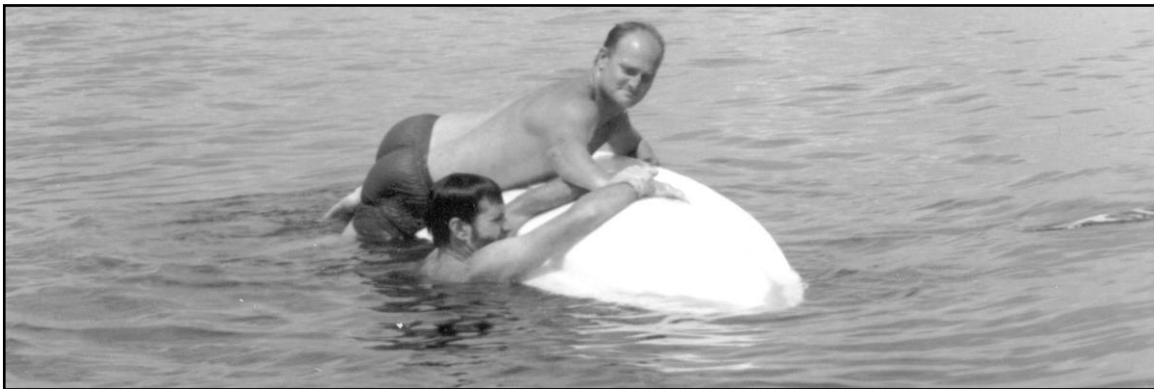

**P-12K**

- e. Place victim's arms halfway across the bottom of the kayak about 24 inches from the bow (P-13K) and roll kayak away from victim to its upright position (P-14K).

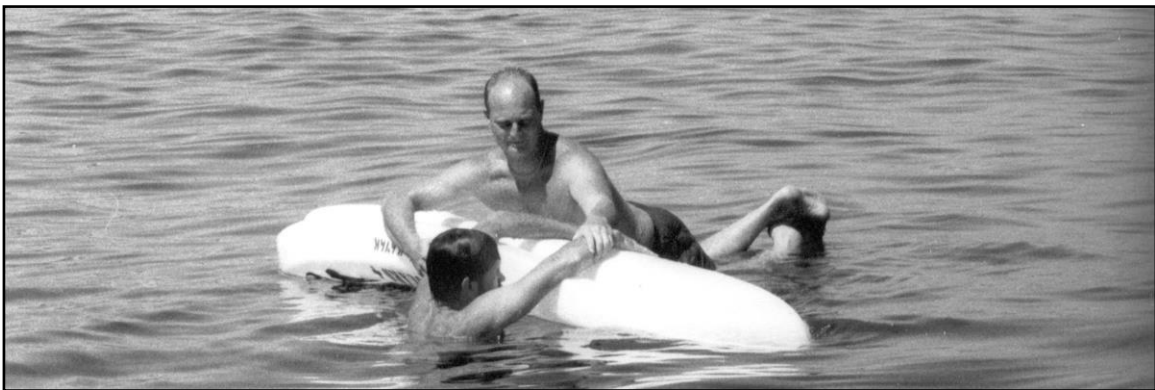

**P-13K**



**P-14K**

- f. The rescuer places one arm on the opposite side of the kayak for stability then climbs into the kayak (P-15K).



**P-15K**

- g. Rescuer straddles kayak and swings victim's legs into kayak (P-16K).

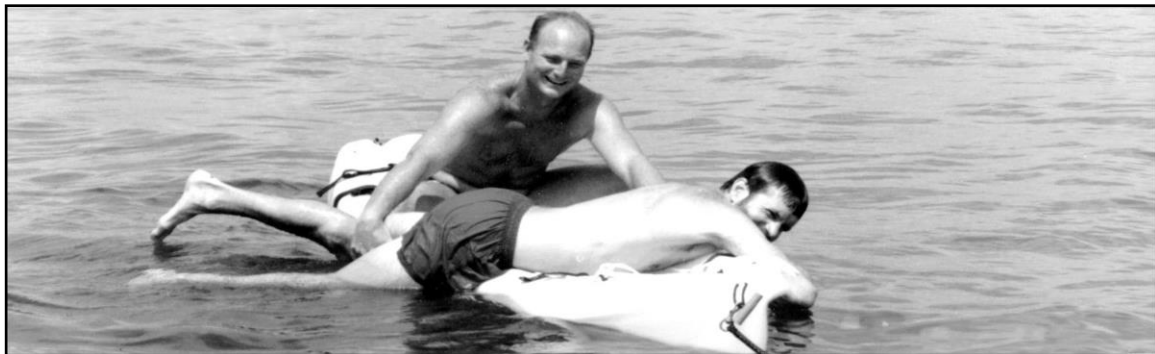

**P-16K**



h. Check for breathing, give appropriate signals to shore, and paddle victim to shore (P-18K). or paddle victim to shore (P-17K).



**P-17K**

### 3. Multiple Victims

Rescues when more than one victim are in close proximity. Below are some common procedures for multiple victims, however, multiple victim rescues are not always textbook cases and judgment is required.

- a. A lifeguard will approach the most distressed victim first. The lifeguard will then approach and assist the other victim(s) with the previously assisted victim(s) still hanging onto the kayak for support. In some situations, it is faster for the rescuer to enter the water and bring additional victims to the kayak rather than bringing the already burdened kayak to the additional victims. **Judgment is required!**
- b. Two conscious victims may be brought aboard kayak (P-18K) (P-19K) or they may hang from the bow and stern of the kayak (P-20K). Rescuer paddles from normal paddling position.



**P-18K**



**P-19K**



**P-20K**

- c. With two or more conscious victims, victims should hang onto the sides of the kayak so the kayak is balanced.
- d. A multiple victim rescue when one victim is in serious condition. Give the tired victims a rescue buoy while getting the most distressed victim into the kayak (P-21K). The most distressed victim will be brought to shore in the kayak while other lifeguards tend to the additional victims.

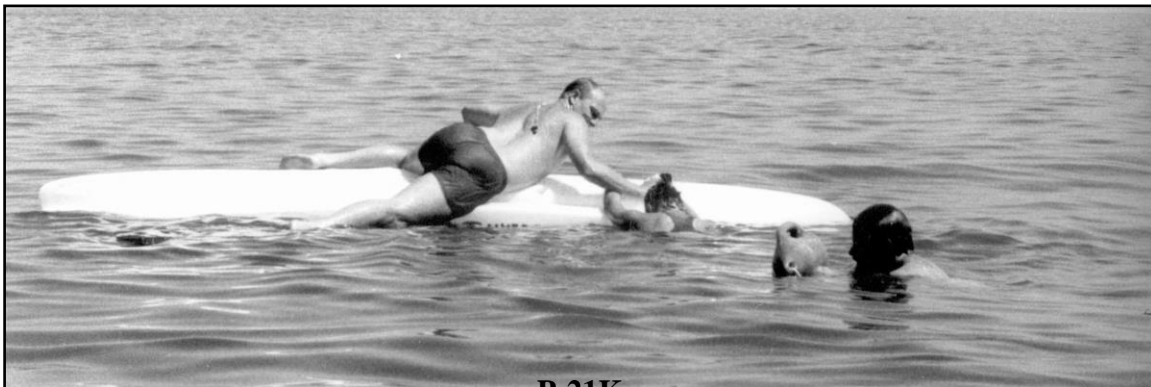

**P-21K**

- e. When there is a multiple victim rescue, additional lifeguards with equipment should respond.
- e. Proceed to shore as quickly as possible.

## V. RESCUE BOARDS

The present rescue board is between 10'6 and 12 feet long, It travels faster than a swimmer and will support several victims.

### A. Regulations

1. Rescue boards not in use, should be kept next to lifeguard stands or directly behind the lifeguard stands.
2. Rescue boards should be distributed evenly on the beach.
3. Rescue boards should always be carried, not dragged.
4. Rescue boards should not be used in any way that may create a hazard to any person. Care must be taken not to run into or over any person with board because an injury may occur.
5. Upon closing each evening, rescue boards are to be carried to the designated storage area and properly stowed.

### B. Use of the Rescue Board

1. When to use:
  - a. For deep water patrol.
  - b. On rescues where long distances must be covered in the water.
  - c. Rescues with multiple victims.
  - d. On rescues where large amounts of debris or weeds are present.
  - e. In assisting capsized or disabled boats provided the bathing area is sufficiently protected.
2. When inadvisable to use:
  - a. Within crowded areas.
  - b. On rescues that would require the board to be carried long distances.
  - c. On rescues within the surf line.
  - d. On rescues where large surf is present.
  - e. When lifeguard is not proficient for conditions, a torpedo buoy is recommended for rescue.

## A. Getting to the Victim in the Ocean

To the extent possible the rescuer shall maintain visual contact with the victim.

1. Entering the ocean with the rescue board.
  - a. Hold the surfboard by the handles. Run down the beach while controlling the board in wind and avoiding patrons (P-1).



**P-1**

- b. Approach the shore break in a running crouch. Throw your shoulder and side into the wave and drive through with your legs while controlling the board with its handles. Be sure to keep the board perpendicular to the oncoming waves. Use your momentum (body weight and your velocity) in moving through the shore break or wait for a lull (P-2).



**P-2**

2. Paddling to the Victim

- a. When the water becomes deep enough the guard mounts the board and adjusts his/her weight so the board is balanced and the nose of the board is 1/2" to 1" above the surface of the water. Always keep the rescue board perpendicular to the oncoming waves.
- b. The guard may paddle the rescue board in the prone position or kneeling. When paddling in the prone position an alternate arm stroke is used. When paddling in a kneeling position a simultaneous arm stroke is used (P-3), (P-4).



**P-3**



**P-4**

- c. To make small change in directions shift weight or drag a hand on the side, you wish to turn. To completely turn the board around move to the rear of the board, sit up and use hands and legs to achieve desired direction.

3. Paddling through the Waves: When taking a rescue board through white water and waves always keep the board perpendicular to wave and use one of the following methods:

- a. "Push-ups"-as wave hits board push up to allow water to pass between your body and board (P-5).



**P-5**

- b. “Turtle”-roll board over right before a wave hits. you are now under the board and underwater holding on to the handles while your legs cling to the board. Right the board and proceed when wave has passed.
- c. Go to the front of the board and dive under wave.

D. Making the Rescue

1. Tired Swimmer Rescue

- a. The rescuer makes the approach so that the victim is either on the left or right side of the board (P-6).

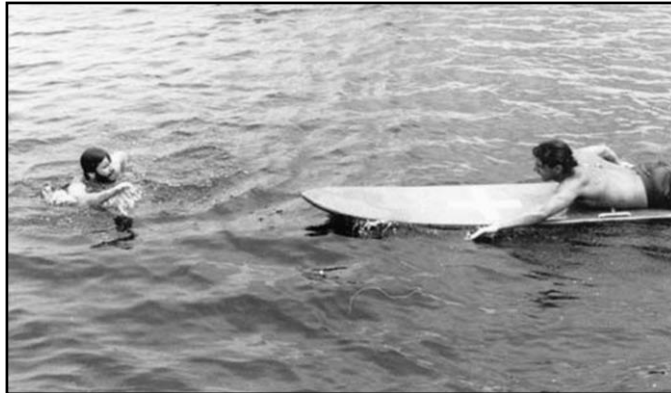

**P-6**

- b. The victim grabs the board and the rescuer slides his or her legs off the board away from the victim so that the board is lying across the middle of the board facing the victim (P-7).



**P-7**

- c. The rescuer now grabs the victim by the arms and pulls the victim onto the board while sliding backwards off the other side (P-8).



**P-8**

- d. The rescuer swings the victim's legs onto the board (P-9).



**P-9**

- e. The rescuer then gets on the board behind the victim and paddles to shore (P-10), (P-11).



**P-10**



**P-11**

2. Unconscious Victim

- a. The rescuer makes the approach so that the victim is either on the left or right side of the board (P-12).



**P-12**



- b. The rescuer slides off the board opposite victim, capsizing the board at the same time (P-13). The board is now upside down between the rescuer and the victim. The rescuer should reach across the board and grab the victim's arms (P-14).



**P-13**



**P-14**

- c. The victim's arms are placed across the board (P-15) and the board is rolled toward the rescuer to its upright position (P-16) thereby rolling the victim across and onto the board.



**P-15**



**P-16**

- d. The rescuer mounts the board, rotates the victim (P-17) (still in prone position) so that the victim's head is toward the front and paddles to shore (P-18). Give appropriate signals to shore and paddle victim to shore.



**P-17**



**P-18**



### 3. Multiple Victim Rescues

Rescue board rescues when more than one victim are in close proximity.

- a. A lifeguard will approach and assist the victim in the most trouble first. The lifeguard will then approach and assist the other victims with previously assisted victims still using the rescue board for support. In some situations it is quicker to bring additional victims to the rescue board using non-equipment rescue techniques (Chapter 9 American Red Cross Lifeguarding Textbook) than bringing a burdened rescue board to the other victims. Your judgment is required in effecting multiple rescues.
- b. Conscious victims in a multiple rescue can hang on to the side of the rescue board.
- c. Unconscious victims in a multiple rescue must be put on top of the board or held on the side of the board by a lifeguard.
- d. When there is a multiple victim rescue additional lifeguards and equipment should respond including a line buoy.
- e. To proceed to shore the lifeguard can best control a rescue board with multiple victims from the rear. Conscious victims may help propel the rescue board to shore or the lifeguard may signal for a line and get pulled to shore.
- f. When using the line buoy to be pulled to shore the line buoy guard must first clip the line buoy to rear of rescue board and then signal to be pulled in. When this procedure is used the rescue board comes in backwards.

### E. Returning to Shore with the Victim

1. Keep board perpendicular to waves at all times and paddle to shore or call for line.
2. Keep victim's weight and your weight back on the rescue board so, it does not pearl.
3. Inform victim when a wave is approaching.
4. Hold on to victim and board as a wave hits.
5. It is better to miss a wave than endanger victim trying to catch a wave.
6. Dismount board when you can stand and assist victim to shore.
7. Alternate method for returning multiple conscious victims to shore:

- a. Keep board parallel to shore.
  - b. Keep victims on seaward side of board. (A large amount of weight on the seaward side will prevent it from capsizing).
  - c. Victims and guards will kick in or be pulled in by line.
8. Be Careful!

F. Care of the Rescue Board

1. The rescue board should be checked daily for any cracks or holes in the fiberglass. Water will seep through cracks and ruin the board.
2. Upon finding damage to a rescue board it should be repaired or replaced immediately.
3. Always keep a coating of surfboard wax or paraffin on the top side of the rescue board.
4. Avoid injuries and damage to the board by placing it in a secure position so that it will not fall.

V. TORPEDO BUOYS (Torps)

Torpedo buoys (rescue-cans) are 34 inches long and have a sling to tow the buoy while swimming. They are designed to support more than one victim if necessary and they are used on all swimming rescues.

A. Regulations:

1. Each torpedo buoy will be checked at the beginning and end of each day for damage. Damage will be reported immediately through the chain-of-command.
2. Torpedo buoys should never be used as anything but flotation devices.
3. Torpedo buoys should never be used by unauthorized persons for any reason.
4. Torpedo buoys on a stand must have the sling easily accessible.
5. Torpedo buoys will be carried by guards on shallow water patrol.

B. Use of the Torpedo Buoy:

1. When to Use:
  - a. For rescues in the bathing area
  - b. On multiple victim rescues
  - c. For long distance rescues when a kayak is not available or practical.

2. When not advisable to use:
  - a. For rescues where a long water distance must be covered, when a kayak is available. If a kayak or a boat is not available, you must swim and take a torpedo buoy.
  - b. For rescues where pollution, hazardous materials or dense seaweed are present.

C. Torpedo Buoy Rescues:

1. When a lifeguard observes a potential rescue, they should stand up. (P19). This is to alert the other lifeguards to a potential rescue.
2. When the rescuer is going out for a rescue, they put on the torpedo buoy sling and holds the torpedo buoy while running through the shallow water (P-22). When the water becomes too deep for running, he drops the torpedo buoy to his side. This procedure will keep him from getting entangled in the torpedo rope (P-23).
3. When the water is too deep to run the rescuer dolphins until swimming becomes faster (P-24).

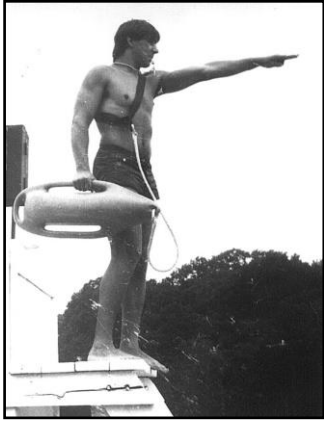

**P-21**



**P-22**

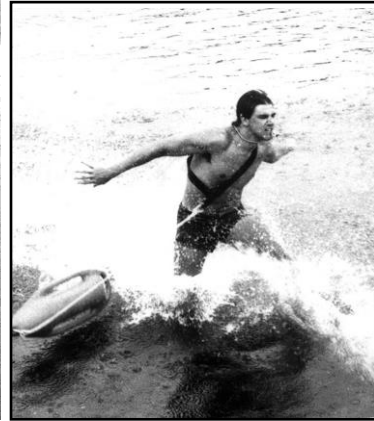

**P-23**

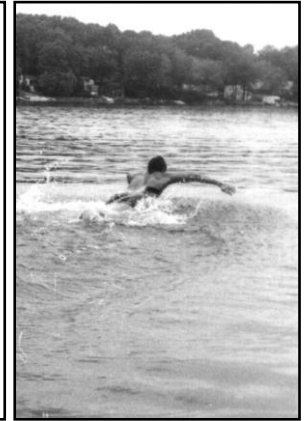

**P-24**

4. Conscious Victim

- a. The rescuer stops just out of reach of the victim and puts the torpedo buoy between them and the victim (P-25). When the victim grabs the buoy, the rescuer can proceed to the shore (P-26).
- b. If the victim is weak, the guard goes behind the victim and secures the victim on the buoy before returning to shore (P-27).
- c. It is important to talk to the victim during this process. Explain what you are doing, and assure them that everything will be fine.



**P-25**

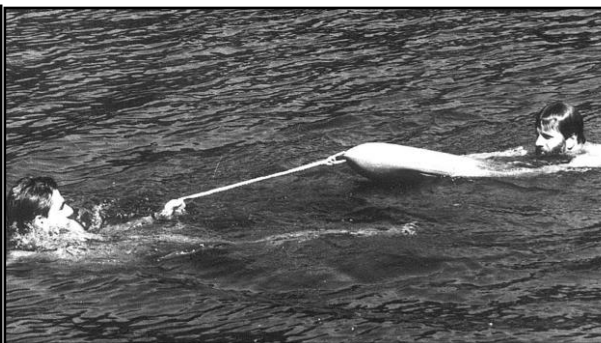

**P-26**



**P-27**

## 5. Unconscious Victim

Place victim's arms on top of the buoy with victims back to the rescuer (P-28). The guard then puts his arm under the victim's armpit and holds the buoy against the victims chest (P-29). Check breathing and signal to shore as appropriate. (Ref. USLA Manual)

Then proceed to shore.



**P-28**



**P-29**

6. Multiple Victim Rescues - Torpedo Buoy rescues when more than one victim is in close proximity.
  - a. A lifeguard will approach and assist the victim in the most trouble first. Additional victims may be assisted by bringing the buoy to the victim or bringing the victim to the buoy using non-equipment rescue procedures. Your judgment is necessary with multiple victims because every situation is different.
  - b. Conscious victims may hang on to the buoy in a multiple rescue.
  - c. Unconscious victims must be held onto the buoy by a lifeguard.
  - d. When all victims are secure, the lifeguard and victims may proceed to shore.
  - e. When there is a multiple victim rescue, other lifeguards with additional equipment should assist.

## VI. Backboards and Cervical Collars

### A. Backboards and Cervical Collar uses:

1. Backboards can be used as a stretcher whenever a victim must be moved from the water, the beach or the picnic area.
2. A backboard must be used whenever there is a victim with a suspected neck or back injury in the water. If the victim with the suspected neck or back injury is on land, the lifeguard should assess the extent of the injury. If the victim is in no immediate danger of further injury, the victim should not be moved until rescue squad personnel arrive and administer to the victim.

3. If the victim complaining of neck and back injuries is standing, you may consider a standing backboard or hold in line stabilization until the rescue squad arrives.
4. Cervical collars are to be used in conjunction with the backboard to immobilize the neck in any injury when there is a suspected back or neck injury.

B. Suspect neck and back injuries if:

1. The victim is unable to move either arms or legs after the accident.
2. The victim has severe pain and spasms of the neck muscles.
3. The victim has difficulty in moving his/her head.
4. The victim complains of numbness or the loss of feeling.
5. The victim has experienced trauma.

**NOTE:** Neck and back injuries resulting from water accidents require special first aid measures because cervical spine (neck and back) fractures are complicated by the possibility of drowning.

Cervical spine injuries are more likely to cause paralysis than any other type of injury. Therefore, it is imperative that the lifeguard take extreme care when tending to a victim with this kind of injury.

When neck or back injuries are suspected, the first lifeguard reaching the victim will alert the other guards using the proper hand signal requesting a backboard and cervical collar.

The victim who has a suspected neck or back injury should not be removed from the water without being properly secured to a backboard, provided there are no extenuating circumstances.

C. Removal of a victim with a neck or back injury floating face up in the water. (Head-and-Chin Support or vice grip method).

1. The lifeguard approaches from either side of the victim (fig. 9-19).
2. The lifeguard places a forearm along the length of the victim's sternum. The hand of the forearm that is against the victim's chest supports the victim's chin. The thumb of that hand is on one side of the victim's chin and the fingers are on the other side (fig. 9-20).
3. The lifeguard's other forearm is simultaneously placed along the length of the victim's spine. The hand of this arm supports the victim's head at the base of the skull by using the thumb on one side of the head and the fingers on the other side (fig. 9-21).

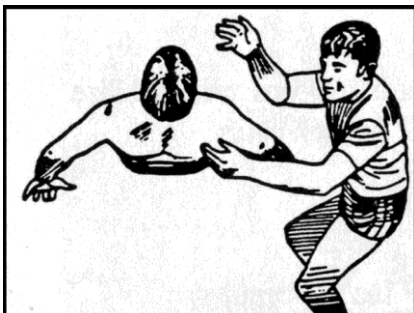

fig 9-19

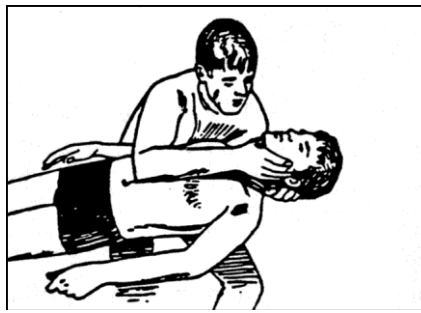

fig 9-20



fig 9-21

4. Both of the lifeguard's wrists are locked and the forearms are squeezed together with inward and upward pressure.
5. The victim can be supported or towed to shallow water in this position to await backboard and cervical collar, to prepare victim for removal from water. Fins are helpful.

D. Removal from the water of a victim floating face down with a suspected neck or back injury. (Head and Chin Support Technique)

1. The lifeguard's approach and hand and arm positioning are identical to the procedure described for the victim found in a face-up position (fig. 9-22, 9-23, and 9-24). It may be necessary to reposition the victim's arm nearest the lifeguard in order to assume the proper hand positions. The victim's near arm should be between the lifeguard's chest and the victim's side.

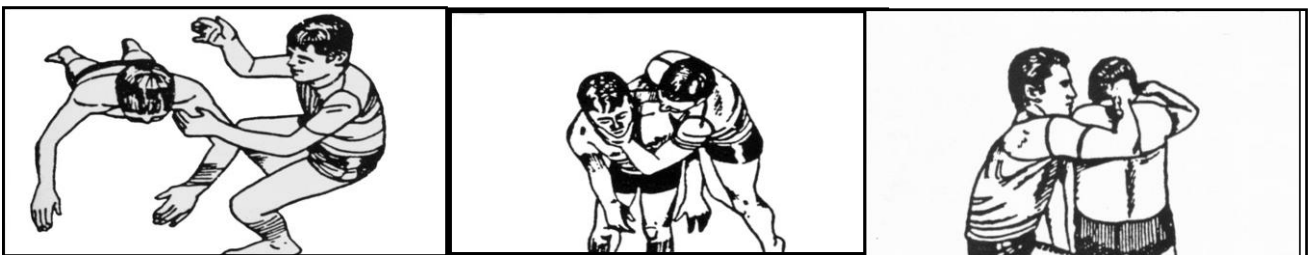

fig 9-22

fig 9-23

fig 9-24

2. To turn the victim to a face-up position, the victim is rotated toward the lifeguard (fig.9-25). The lifeguard submerges during this step and surfaces when the victim is face up in the water. The victim should now be glided to a horizontal position. If deeper water is needed to turn victim, while sandwiched between your arms, move to deeper water.
3. This step may be performed while standing in place (fig. 9-26) or while moving in a headfirst direction (fig. 9-27).

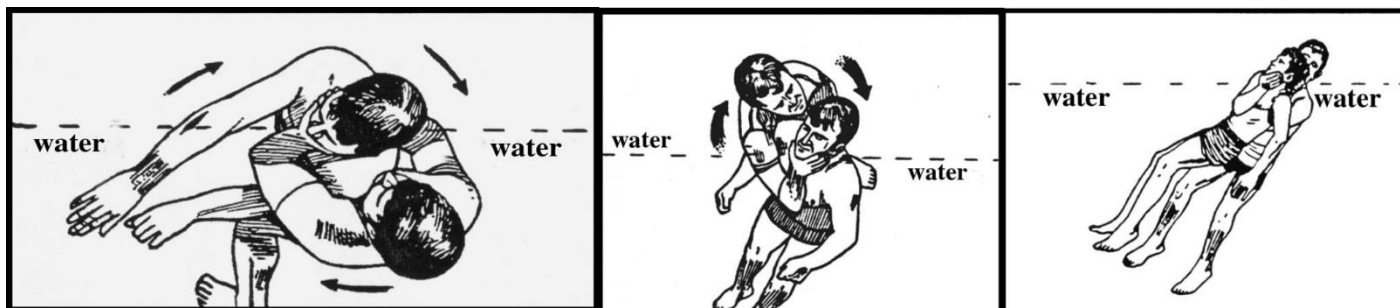

fig 9-25

fig 9-26

fig 9-27

4. This movement must be done slowly to prevent any movement of the lifeguard's arms and hands and also to reduce any drastic twisting of the victim's hips and legs.
5. The victim can be supported or towed to shallow water in this position to await backboard and cervical collar to prepare victim for removal from water.

NOTE: The head-and-chin support technique can also be used with a victim who is submerged and who may be lying on the front, back, or side of the body. The steps are performed as described previously, and the victim is brought to the surface. The lifeguard can then tow the victim to shallow water using this technique. However, extreme caution must be exercised to prevent any movement of the victim's head or neck.

- E. Placing the victim on a backboard and securing the victim to the backboard.
  - 1. Before the victim is placed on the backboard the base of the head immobilizer must be secured to the backboard using the following procedure.
    - a. Place the base of immobilizer on the backboard with the face up (P-30).
    - b. Put the buckled strap through the hole at the top edge and in the center of the board and buckle it (P-31).
    - c. Take the remaining Velcro straps and put them around the board and fasten them to the Velcro pads. The immobilizer is now ready for use (P-32).



**P-30**

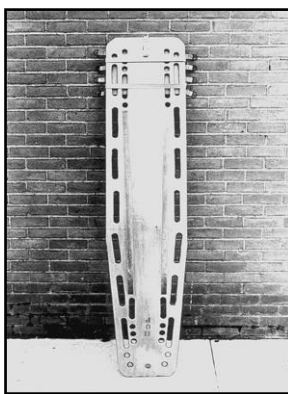

**P-31**

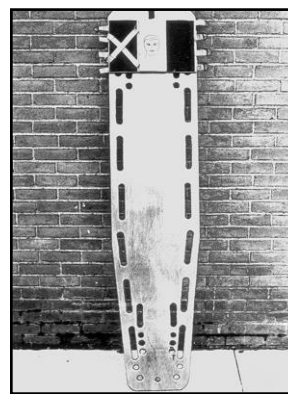

**P-32**

- 2. With the victim now face up (P-33), a second lifeguard will hold the head in alignment as a third lifeguard, who has a backboard with the head immobilizer base already in place, submerges the board and allows it to float up under the victim (P-34).



**P-33**



**P-34**



3. a. Once the backboard is in position with the victim's head centered on the head immobilizer place the proper size cervical collar on the victim (P-35), while someone continues to hold the head and neck in alignment.  
Note: If necessary remove earrings before applying cervical collar.

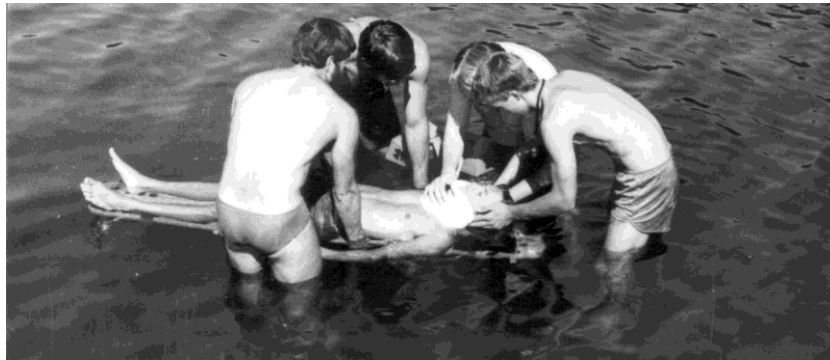

**P-35**

- b. The following diagrams describe use of the cervical collars

# STIFNECK

Original Stifneck Extrication Collar  
Original Select and Pedi-Select Extrication Collar

ENGLISH

## 1 Measure the patient

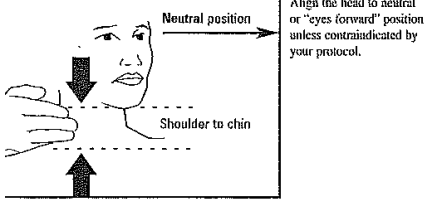

## 2 Match the collar size to the patient

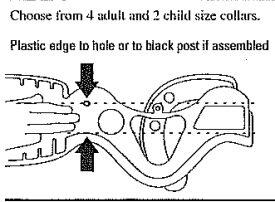

**Stifneck Original Collar**

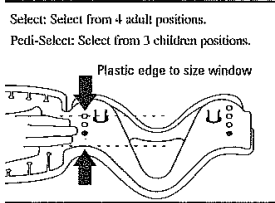

**Select/Pedi-Select Adjustable Collar**

Same basic method of adjusting for both Collars.

## 3 Assemble the original collar

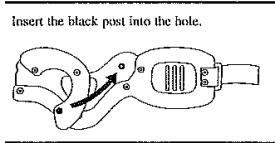

**Stifneck Original Collar**

## or Adjust and Lock the adjustable collar

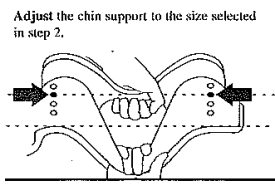

**Select/Pedi-Select Adjustable Collar**

Same sizing method for Select and Pedi-Select

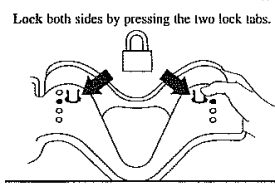

## 4 Preform the collar

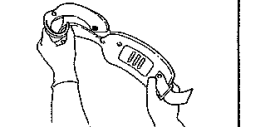

## 5 Apply the collar while manually maintaining neutral head position



Place the chin support well under the chin. If a different size is needed, remove, re-size, and re-apply the collar.

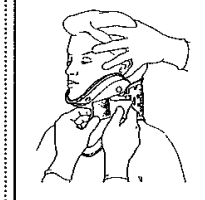

Pull the back of the collar snug while holding the front in place, then fasten.

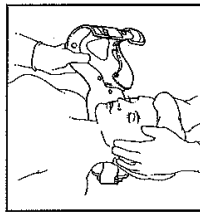

For a supine patient, slide the rear panel behind the neck before placing the chin support.

**Important:** Do not adjust the Select/Pedi-Select collar on patient.

**Storage:** Do not store collar in folded position. Store flat.

## IMPORTANT

**Warning:** To insure proper use, please review all material in this DFU. All Stifneck products should only be used by persons who have received adequate training. In cases of suspected spinal injury, proper cervical immobilization is only one part of an immobilization system. It is important that the patient be properly immobilized to prevent movement of the spine (per local protocol). Do not use an improperly sized collar. Too large a collar may hyperextend a patient's cervical spine; too small a collar may not provide appropriate stability. Special sizes of Stifneck collars are available for children and others with small bodies.

## WARRANTY

Please see the Global Warranty statement for terms and conditions.

[www.laerdal.com](http://www.laerdal.com)

Storage Temperature Range:  
-34°C to 52°C (-30°F to 125°F)  
Operating Temperature Range:  
-18°C to 43°C (0°F to 110°F)



**CE** The product is in compliance with the essential requirements of Council Directive 93/42/EEC Medical Devices Directive.

4. Secure the upper body to the backboard first by using straps or cravats (P-36).



**P-36**

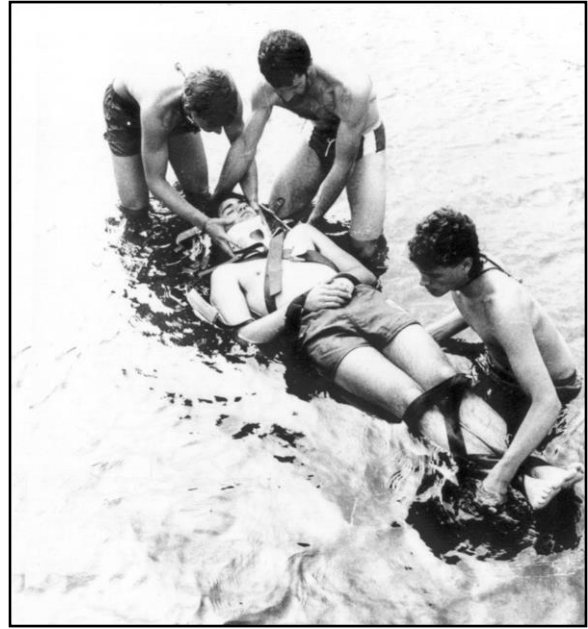

**P-37**

5. Tie the rest of the body to the backboard with the straps or cravats at the hips, thighs and shins (P-37).

6. Secure the feet using a figure eight with straps or cravats (fig. 9-53).

**BOTH FEET WOULD BE TIED  
IN A SIMILAR MANNER**

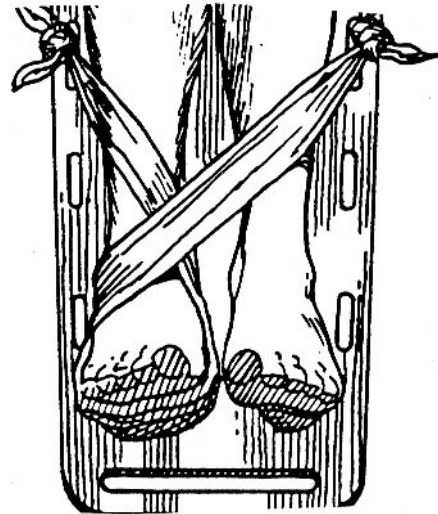

**fig 9-53**

**Note:** E-4, E-5 and E-6 are performed while someone continues to hold the head and neck in alignment. A spider strap may be used instead of straps and cravats. A spider strap may not work on all victims.

7. The head is now secured by placing the rubberized immobilization blocks one at a time next to the victim's head with the holes lined up by the victim's ears. To place a block in position next to the head, the guard holding the head in alignment moves one hand as a block is put on one side of the head (P-38). The same procedure is repeated with the second block. The guard that was holding head alignment is now holding support with both hands on the immobilization blocks (P-39).

Next, take one of the foam rubber straps and place it over the center of the forehead. Fasten the strap using the rings on the head immobilizer base and the Velcro strap ends. The strap should be snug. The second foam rubber strap goes under the chin on the cervical collar and is fastened to the head immobilizer base in the same manner as the first strap (P-40).



**fig P-38**

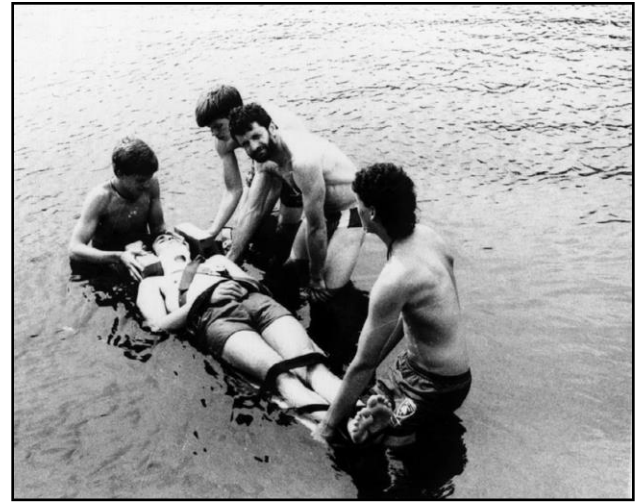

**fig P-39**

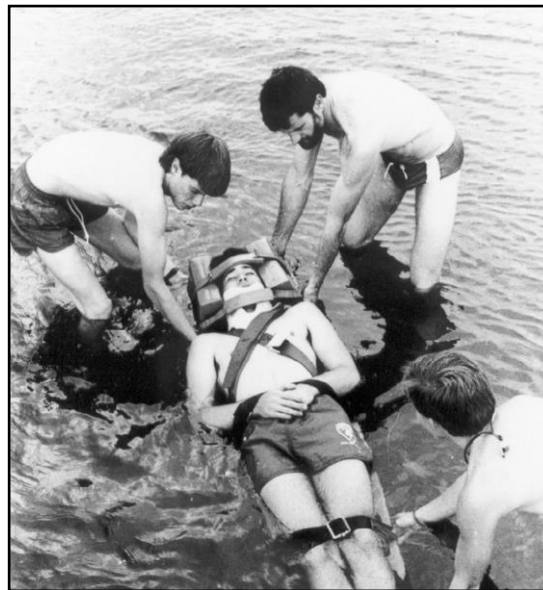

**fig P-40**

8. The victim is now completely secured is removed from the water to the beach. Further movement should be done by the ambulance crew.

**NOTE:** Work as rapidly as possible but avoid any unnecessary movement of the victim.

When the water is very cold, when there is excessive bleeding or no breathing, the victim should be removed from the water after the backboard and cervical collar are in place. The victim can be secured to the board on land. Use blankets to warm the victim.

If the victim is not breathing, rescue breathing, using the jaw thrust method should be begun at once. The board and collar can be put in place while this is being done. Move the victim to land as quickly as possible. For more information on this subject, all guards should read Chapter 12 of the Red Cross Lifeguarding Textbook.

- F. 1. When a neck or back injury is suspected in extremely shallow water with the victim's face up, one guard should hold the head in alignment while a second guard puts a cervical collar on the victim (P-40B). (Remove earrings first.) Await the rescue squad to move the victim any further. Cover the victim with a wool blanket because wool still insulates when wet. If the victim must be moved immediately, the procedure will be discussed in F-3.



**P-40B**

2. When the victim is face down in very shallow water with a suspected neck or back injury, where the head and chin support method can not be used, the situation is complicated because the victim must be rolled over to allow breathing while maintaining the neck and back alignment (P-40C).
- a. To administer to this situation, two lifeguards are needed. One guard holds the head and neck in alignment. The second guard moves the victim's arm overhead on the side the victim will be rolled (P-40D). The second guard now positions one hand on the victim's shoulder and the other one on the victim's hips (P-40E). The victim is now rolled over using the method learned in CPR/ First Aid, move near arm next to head. Position your arms on victim's shoulder and hips, being careful to keep the neck, head and back aligned roll victim over. (P-40F). This must be completed with care and promptness to allow the victim to breath.



**P-40C**



**P-40D**



**P-40E**



**P-40F**

- b. When the victim is face up, the guard holding the head alignment has his/her arms twisted (P-40G). This is a difficult position to hold for an extended period of time. You may reverse your hands prior to rolling the victim if you chose and then your hands won't be twisted.

To correct this situation the second guard places his/her hands over the hands of the first guard (P-40H) and holds alignment while the first guard slips his/her hands out. The first guard then puts his/her hands over the hands of the guard now holding alignment so they can release their hold to allow them to place proper size cervical collar on the victim (P-40I). The guard at the head is now holding alignment again (P-40J). The cervical collar is now put in place (P-40K). (Remove earrings first.) A guard should continue to hold alignment on the head until the rescue squad arrives and prepares victim for further movement. A wool blanket can be used to keep the victim warm.



**P-40G**



**P-40H**



**P-40I**



**P-40J**



**P-40K**

3. If the victim must be moved from shallow water (lightning, victim cold) before the rescue squad arrives, the following procedure should be used:
  - a. With one guard holding the head in alignment with the cervical collar already in place, a second guard prepares to roll the victim by placing the victim's arm above his/her head on the side the victim will be rolled. This guard now positions his/her hands



on the shoulders and hips in order to roll the victim (P-40L). The victim is now rolled enough to slide the backboard under the victim (P-40M). The victim is now lowered onto the backboard. This is done gently while keeping the head, neck and back of the victim aligned (P-40N). If further adjustments of the victim are required, maintain in line stabilization.

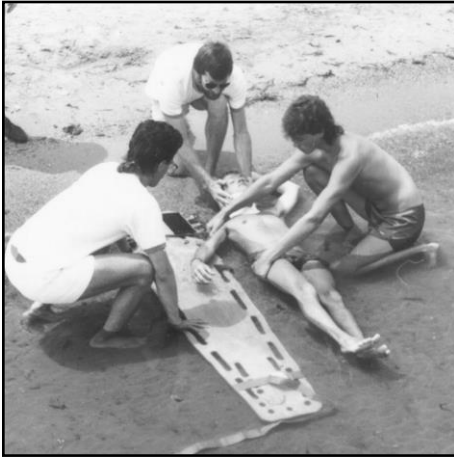

**P-40L**



**P-40M**



**P-40N**

- b. The victim is now secured to the backboard as described in procedures E-4 to E-8 in this backboard section. The victim can now be moved out of the shallow water (P-40 (O)). Sometimes it is best to move the victim on the backboard to land before securing straps. Good judgment is required.



**P-400**

- G. Victim is standing and complains of symptoms of a neck or back injury.
1. A guard will hold the head and neck in alignment while facing the victim. (P-1)
  2. When the immobilization equipment arrives, a second guard will apply the correct size cervical collar as described in Section G. (P-2)

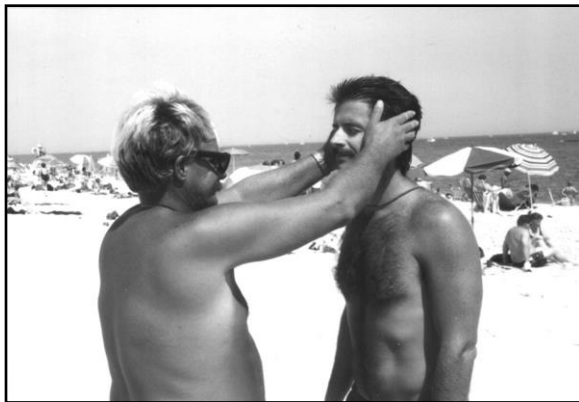

**P-1**

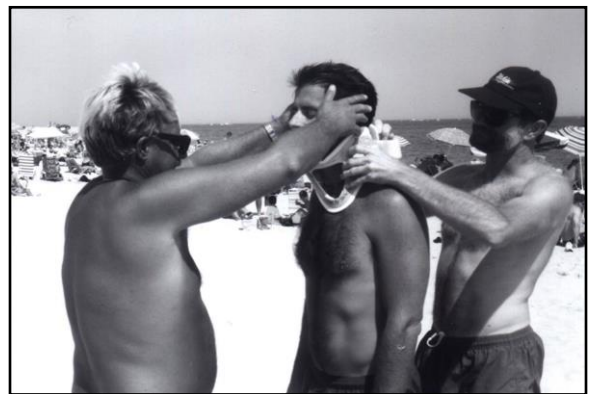

**P-2**



**P-3**

3. A guard will now place the backboard behind the victim. (P-3)
4. Two guards will now hold the head and neck in alignment while holding the back board against the victim's back. One guard on each side of the victim will hold the backboard with his/her arm through the victim's armpit, while the guard's other arm holds the victim's head in alignment. (P-4).



**P-4**

5. A third guard will go behind the victim and backboard. While holding the top of the backboard, this guard will lower the backboard to the ground while the other two guards hold the board while maintaining in line stabilization. (P-5)



**P-5**

6. When the victim and board are on the ground, the two guards maintaining in-line stabilization will release the head as the third guard takes over the head alignment.
7. The victim is now secured to the backboard with straps from the chest to the feet followed by head immobilization. The victim is ready for transport.

## VII. POCKET MASKS AND BAG VALVE MASK (BVM):

- A. Pocket masks and BVM are devices designed to fit over the mouth and nose of a victim that has stopped breathing. These masks are to be used while performing rescue breaths or CPR, to prevent transmission of communicable diseases when doing ventilations on a victim that has stopped breathing.
- B. All pocket masks and BVM will be used according to approved techniques taught by the American Red Cross.
  1. To review proper use of the pocket mask or BVM, consult American Red Cross CPR/AED for the Professional Rescuer textbook.
  2. Each rescuer giving ventilations should use his/her own pocket mask.
- C. Regulations:
  1. At least one pocket mask, adult BVM and child BVM shall be kept at each lifeguard stand.
  2. Every First Aid Room shall have at least one pocket mask adult BVM and child BVM.

3. When a pocket mask or BVM is discarded, it will be replaced as soon as possible.

D. Care:

1. Pocket masks, valves and BVM used in training should be cleaned. Wash and scrub in warm soapy water. Rinse in clear water. Soak for 10 minutes in 1:64 bleach water solution. Rinse and allow to air dry.
2. When a pocket mask or BVM is used on a real victim, the mask and valve should be discarded. Request a replacement from the ambulance.

VIII. Beach Wheelchair

This is a chair designed to be used by persons with disabilities on the beach. It is not to be taken into the water. When not in use, the Beach Wheelchair may be useful in removing injured patrons from the beach.

A. Use of the Beach Wheelchair

1. The wheelchair can be signed out on a first-come, first-serve basis for one-hour periods. All sign outs must be done on Beach Wheelchair Sign Out Sheet.
2. The area employee who handles Beach Wheelchair sign out is determined by the Superintendent.
3. Lifeguards must be aware of the sign out process, who does it and other wheel chair regulations.
4. Users and attendants of Beach Wheelchairs must be advised of the following:
  - a. When going down a slope, attendant and wheelchair must go backwards.
  - b. How to apply the parking brake.
  - c. Weight limit is 300 pounds.
  - d. An attendant is required to move the Beach Wheelchair. If a person needs an attendant, non-lifeguard personnel may be used.

B. Care of the Beach Wheelchair

1. Air pumps and needles like those used to inflate a basketball are needed to pump up the tires. Tire pressure is 3 pounds.
2. Report any damage (flat tires, etc.) to the Superintendent immediately, so it can be fixed.

IX. Mask, Fins and Snorkel

Mask, fins and snorkel can be used separately or together. They are for use in recovering submerged victims or objects.

## A. Mask

1. Defogging - fogging of mask can be prevented by rubbing saliva on the inside of face plate followed by rinsing with water.
2. Proper Fit - Move hair off face, place mask on face without straps and inhale slightly. If mask stays on face, it is a good fit. If it is a poor fit, try again, with a different mask. If it is a good fit, adjust the straps for the best fit.
3. Since all lifeguard diving is done without scuba equipment, the mask can be cleared of any water at the surface.

## B. Fins

1. Put fins on while in water deep enough to swim in. If you must walk with fins, it is best to walk backwards.
2. Be sure to wear properly sized fins.
3. When kicking with fins, use a modified flutter kick. A modified flutter kick is a flutter kick that is deeper, slower and with more knee bend.

## C. Snorkel

1. Attach snorkel to side of mask with a clip or by inserting snorkel under mask strap for the stabilization of the snorkel.
2. Hold entire snorkel mouth piece in your mouth and seal off from water.
3. Breath through snorkel only on the surface.
4. When you surface dive into deeper water with a snorkel, hold breath as if you were diving into deeper water without a snorkel.
5. After surfacing following a dive into deep water with snorkel, the water must be cleared from the snorkel to allow breathing again. Clearing the water from the snorkel is accomplished by exhaling forcefully at the surface. Breathing through the snorkel can now be resumed.

## D. Pressure Equalization

Diving from the surface to deep water with or without mask, fins and snorkel requires you to equalize pressure within your ears to the pressure of the water outside of your head.

1. The easiest method for equalizing pressure is by squeezing your nose closed with two fingers through the mask, while closing your mouth and attempting to exhale. If you do not experience equalization, continue until you do so or return to the surface.
2. Equalize as soon as you descend under the water's surface and continue to equalize as you go deeper.

For further information on mask, fins and snorkel, refer to the American Red Cross Lifeguarding textbook, Chapter 10, pages 152 - 158.

X. EMERGENCY OXYGEN

1. Emergency oxygen and related equipment will be stored in the First Aid Room.
2. It is to be used on a victim who has stopped breathing or having difficulty breathing.
3. Emergency oxygen is to be used according to the procedures taught in the ASHI Emergency Oxygen course. The course will be taught with the BLS class. Do not administer oxygen if you don't have the class.
4. The pressure of the cylinder in use will be checked regularly every Thursday. The pressure is recorded in the daily report. If the pressure is below 500 PSI, the cylinder should be changed. When working on a victim, the cylinder should be changed at about 200 PSI.
5. All empty or nearly empty cylinders must be given to the Park Superintendent for prompt refill. Cylinders must be refilled with medical grade oxygen.
6. Oxygen flow should be used as appropriate for the situation according to ASHI Administering Emergency Oxygen Training
7. When a victim is transported with mask, request a replacement mask from the ambulance.
8. Masks and cannulas used on victims must be discarded.

XI. AUTOMATED EXTERNAL DEFIBRILLATOR (AED)

1. To be stored in first aid room.
2. AED to be used according to procedures learned in American Red Cross CPR/AED for Professional Rescuer course. To use an AED your CPR/AED card must be current.
3. Check AED every Monday and record status in the AED log.

# **PROCEDURES**



## I. OPENING AND CLOSING

- A. All lifeguards are to report to their beach at the designated time. All equipment will be set in place and training will begin.
- B. STATE BATHING AREAS WILL NORMALLY OPEN TO THE PUBLIC AT OR AROUND 10:00 am. Lifeguards going on duty at 10:00 am will call all persons already bathing from the water by whistle blast, warning horns or other suitable devices. Once the water is cleared, an announcement will be made with bullhorns or public-address system stating, "May I have your attention please. Lifeguards are now on duty. Please give them your full cooperation; obey their directions and all area regulations. Bathing area regulations are posted. Enjoy your day."
- C. Beach equipment will begin to be collected one half hour before closing the swim area, provided sufficient personnel are available to do this and still provide adequate lifeguard protection. Torpedo buoys, kayaks and first aid kits will not be removed from lifeguard stands until patrons have left the water. ALL STATE BATHING AREAS WILL NORMALLY CLOSE AT OR AROUND 5:30 PM. Announcements should be made 45 minutes and 20 minutes prior to closing notifying the public the closing time.
- D. At the end of the day or any time bathing area must be closed, lifeguards will call all patrons from the water and make an announcement stating, "May I have your attention please. The lifeguards are now off duty and the bathing area is closed for the day. Bathers may not re-enter the water until 10:00 (or your area opening time) am tomorrow morning."
- E. Lifeguards must change signs to show lifeguards are off duty at the end of the day or any time bathing area must be closed.
- F. If the bathing area is closed prior to scheduled closing time pm the park office must be notified. If the bathing area reopens inform park office.

## II. COMMUNICATIONS

The following signals have been developed so that lifeguards can effectively communicate.

- A. Whistle Signals
  - 1. One blast is used for gaining patron's attention.
  - 2. Two short blasts are used to gain the attention of other lifeguards within hearing range.
  - 3. Three or more rapid short blasts indicate that a rescue is beginning, or other emergency situation exists in the water or on the beach.
- B. Air Horn Signals
  - 1. One blast means lifeguards are needed quickly for a possible submersion.
- C. Hand Signals
  - 1. A hand overhead means a lifeguard needs assistance. It may be used in the water

or on the beach (P-41).

2. Pointing with index finger extended is used to alert another lifeguard of a situation to be watched in his area (P-42).



**P-41**



**P-42**

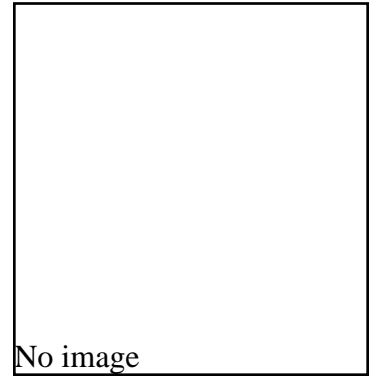

**P-43**

3. Bring backboard, cervical collars and head immobilizer - move both arms up and down simultaneously above your head as if you were doing presses while weight lifting (P-44).



**P-44**

4. Call an ambulance -Extend your arms perpendicular to the front of your body and move them up and down in an exaggerated imitation of steering a vehicle (P-45).



**P-45**

5. CPR needed, bring pocket masks, BVM, oxygen, AED, and call an ambulance by waving one arm over your head (P-46).



**P-46**

6. Call the State Park Police - Tap top of your head (P-47).



**P-47**



**P-48**

7. To call a lifeguard from the water - Blow whistle, move hand in circular motion over your head then motion to come in (P-48).

8. Submersion of victim - lifeguard makes an X with arms overhead (P-49).



**P-49**

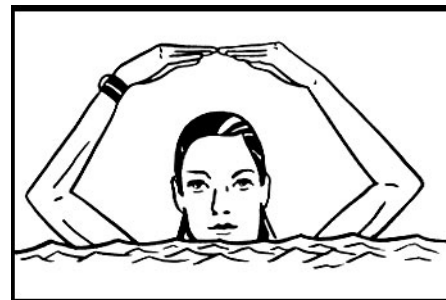

**P-49A**

10. All clear – make an O overhead with arms (P-49 A).

11. To give directions to a lifeguard in the water looking for a victim or to direct a guard with a victim, the signals are basic. Point left for a guard to go left, point right for a guard to go right, point out for a guard to go farther from shore, wave in for guard to move toward beach and show palms of both hands for guard to stay.

D. Radio Procedures

There will be a two-way park frequency radio on all lifeguard stands and in the first aid room. Necessary information and procedures will be explained by the area Superintendent.

III. SUMMONING AID

All emergency telephone numbers should be conspicuously displayed near the telephone. When the aid of an emergency service from outside the area is needed, i.e., ambulance, police, etc., the following steps will be followed:

A. Call the service you need and inform them:

1. Who you are and the area you are in.
2. The reason you called - the injury or incident and the urgency of assistance.
3. The location within the park.
4. Your telephone number.

B. Immediately after the call above, notify the area office of the emergency and request an escort for the responding emergency vehicle(s) and the State Park Police for crowd control.

C. Immediately after the second call, notify the main gate and inform them that an emergency vehicle will be arriving. Inform them of the location of the emergency so that they may provide directions if necessary.

D. Notify the head lifeguard if on duty, but not in the immediate vicinity.

E. Assign a member of the lifeguard staff, if possible to meet the emergency vehicle to assist and guide them to the location of the emergency.

IV. LOST CHILD/PERSON

Any child that appears to be lost is to be delivered to the State Park Police. If the State Park Police are unavailable, or they are not successful in locating the child's parent/guardian, a lifeguard will place the child on or near a lifeguard stand and make an announcement stating, "May I have your attention please. We have found a lost child. Their name is \_\_\_\_\_ (then give a description of the

child). If this is your child, please report to a lifeguard or the first aid room." Everything reasonable should be done by the lifeguard to stabilize the emotional state of the child.

## V. MISSING CHILDREN/PERSONS

When a person has been reported missing, the lifeguard should:

- A. Obtain name and complete description.
- B. Find out where the person was last seen.
- C. Ask if the person has any medical condition(s) and obtain any additional information that may aid in locating the person.
- E. Contact Lifeguards, State Park Police and other necessary park personnel.
- F. Instruct an adult who knows the child to remain at a central location so that they may be contacted as needed.
- G. An announcement should be made stating, "May I have your attention please. We are looking for a lost boy/girl/man/woman (Give a description, i.e. name, age, clothing, physical features). If you find this person, please notify a lifeguard or the first aid room."
- H. If the person was last seen in or near the water, the lifeguards will conduct a water search.
- I. The State Park Police and other park personnel will conduct a land search.
- J. To help prevent lost and unattended children the following announcement may be used:

"May I have your attention please. This park requires that an adult accompany children at all times especially while in the water. Do not leave your children unattended even for a minute. If your children are left unattended you may be asked to leave the park. We ask you at this time to locate your children. Group supervisors and counselors please locate each member of your group. If you have any missing children, please let the lifeguards know at this time. Your children are not only important to you but to the staff at \_\_\_\_\_ park.

## VI. WATER SEARCH

- A. If there is a missing person that was last seen in or around the water, the lifeguards will conduct a water search. Speed and efficiency are vital. The head lifeguard on duty will take charge and direct the search. If necessary, have all bathers clear the water. Only lifeguard staff should be used for the search. An announcement should be made stating, "May I have your attention please, all bathers must leave the water. There is a person missing that was seen in the water and the lifeguards must search the bathing area. (Give name and description of the missing person.) If you know where this person is located, please report to a lifeguard."
- B. When a water search is conducted for a missing person and the person is a very young child, the shallow water should be searched first. The older/taller the person, the farther out the search must be extended. Always start the search where the missing person was last seen. First, cover an area within an approximately 60-ft. radius from where the person was last seen. Then extend the search to the remainder of the bathing area. Shallow parts of

the area, (chest deep or less) should be searched using the human chain method. All searchers line up perpendicular to the beach and walk from one end of the bathing area to the other, moving parallel to the shore. Some bathing areas are an irregular shape and searchers move in and out or perpendicular to shore. Whatever method an area uses it should be efficient and well rehearsed.

- C. If the water is more than chest deep, diving by guards should be utilized to search the area. Rescuers form a line with about three feet between them. The leader may use a kayak or rescue board to coordinate the search. If this is inefficient, the guard at one end is the leader. At the leader's signal, the rescuers surface dive to within one foot of the bottom. They then swim for a predetermined number of strokes, and then they come straight up to the surface, back up three feet, and realign. At the leader's signal, they repeat the process and continue the search until the entire bathing area and 5 yards beyond the ropes has been searched.
- D. When the person has been found, make an announcement stating, "May I have your attention please, the missing person has been found. Thank you for your cooperation. You may re-enter the bathing area." Do not make this announcement until the lifeguards have regrouped and are at their assigned guarding positions (stand or kayak).

## VII. SIGHTED SUBMERSION

This is different than a water search because in this situation, a lifeguard going on a rescue has observed the location of the victim before the victim submerges.

### A. Initial Procedure

1. The first lifeguard arriving on the location where the victim was last spotted should take sightings of landmarks so the spot can be readily identified and marked with an anchored buoy.
2. The first guard and other arriving guards take random dives and search the bottom for the victim.
3. When the guards on the beach see the guard who went on the original rescue diving for a victim, the air horn should be blown (unless another signal is used) and the bathing area should be cleared of all bathers.
4. All available lifeguards report to the scene leaving one guard on each stand until the water is cleared.
5. The area office must be notified that there has been a confirmed submersion so Park Police and an ambulance can be sent to the beach.
6. When enough guards arrive at the location where the victim was last seen, a human chain is to be formed if the water is less than chest deep, or a diving line for deeper water in order to begin a systematic search.

### B. Systematic Search for a sighted submersion (diagrams on pages 69, 70 and 71).

1. The head lifeguard will organize and conduct the search.

2. The head guard lines up the guards parallel to the shoreline, facing the water and approximately 10 yds. inland of the location where the victim was last sighted. The guards will form a line by spreading their arms and touching fingertips. The guard in the middle of the line will line up with the location where the victim was last seen.
3. When the guards are lined up properly, the head guard will give the command "1-2-3 dive." At this command, the entire line will dive, take three strokes along the bottom, then resurface. The line will then move back one body length, reform and dive again. The dive line will continue this procedure of diving until it is approximately ten yards past the location where the victim was last seen. When searching the bottom, the guards must feel with their hands for the victim because visibility is likely to be poor.
4. When the dive line is ten yds. past the spot the victim was last sighted, the guards will rotate according to the following diagrams. After they rotate, the guards will be facing shore ready to start a second pass over the area. The diving line will do dives on this second pass until they are 10 yds. inland of the location where the victim was last seen. Fins may make dive line more efficient.
5. After the second pass over the area, the diving line will rotate again according to the diagram and make a third pass doing dives until the line is 10 yds. past the victim's last sighting.
6. If the diving line does not find the victim after three passes, the guards will split up and cover additional area according to the subsequent coverage diagram.
7. If the victim is not found after a short period of time, the location should be marked with a buoy.
8. Lifeguard Officer must mark and keep track of area searched.

C. Additional information on a sighted submersion

The following diagrams show 5 lifeguards performing the search. This procedure can be performed by a diving line of more or less than 5 guards using the same logic for rotation. This method of search was developed to double check the area closest to where the victim was last seen while enlarging the area being searched. The search is done this way because bodies will drift as they go down, or even while they are on the bottom. The procedures and diagrams for a sighted submersion in the manual are just models. These procedures may vary slightly at each area since the number of guards, beach conditions and communications differ. These procedures should be thoroughly discussed and practiced to fit the needs of each area.

# WATER

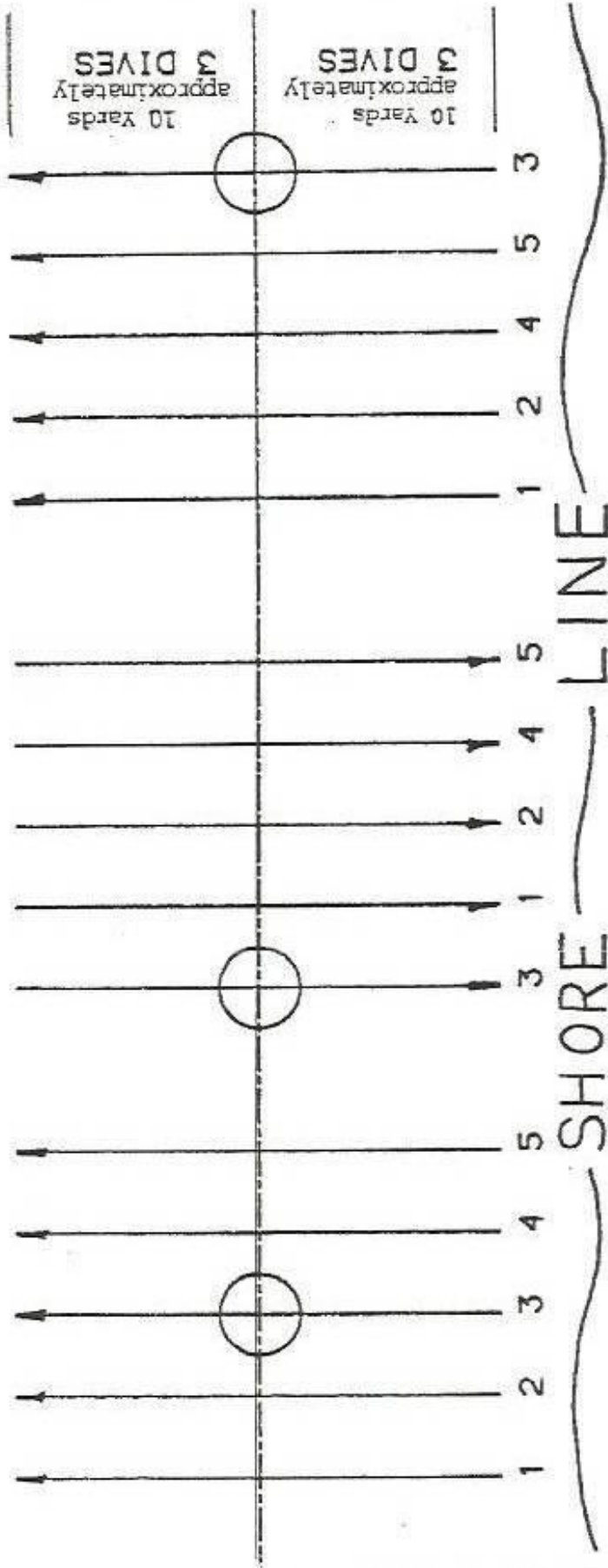

1st PASS

2nd PASS

3rd PASS

THEN ROTATE  
BY NUMBERS

THEN ROTATE  
BY NUMBERS

THEN ROTATE  
BY NUMBERS

INITIAL COVERAGE FOR SIGHTED SUBMERSIONS.



DEEP WATER

1<sup>ST</sup> PASS

2<sup>ND</sup> PASS

3<sup>RD</sup> PASS

3 DIVES/10 YDS.

3 DIVES/10 YDS.

COMPOSITE DRAWING  
OF PAGE 65

SHALLOW WATER

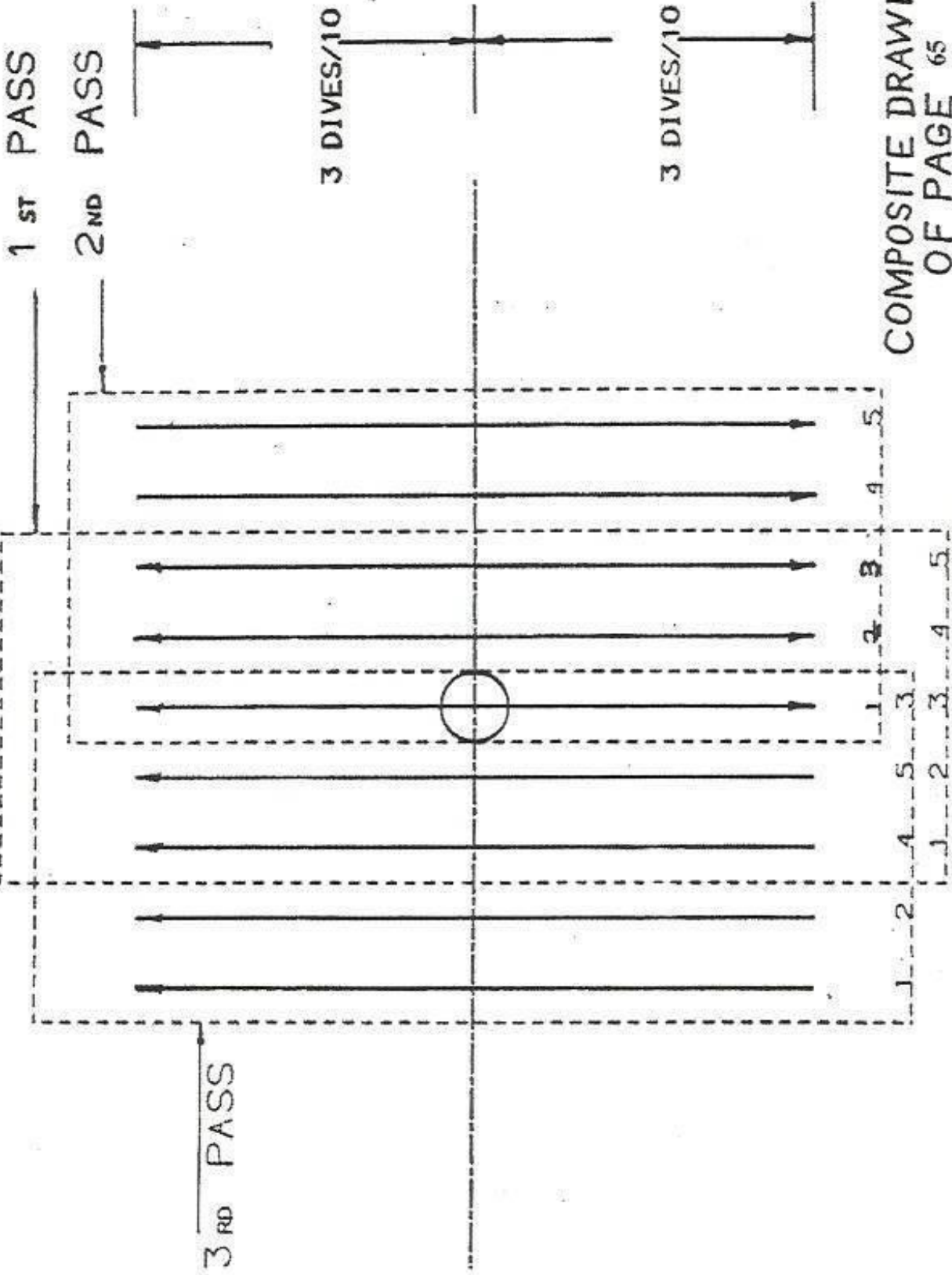

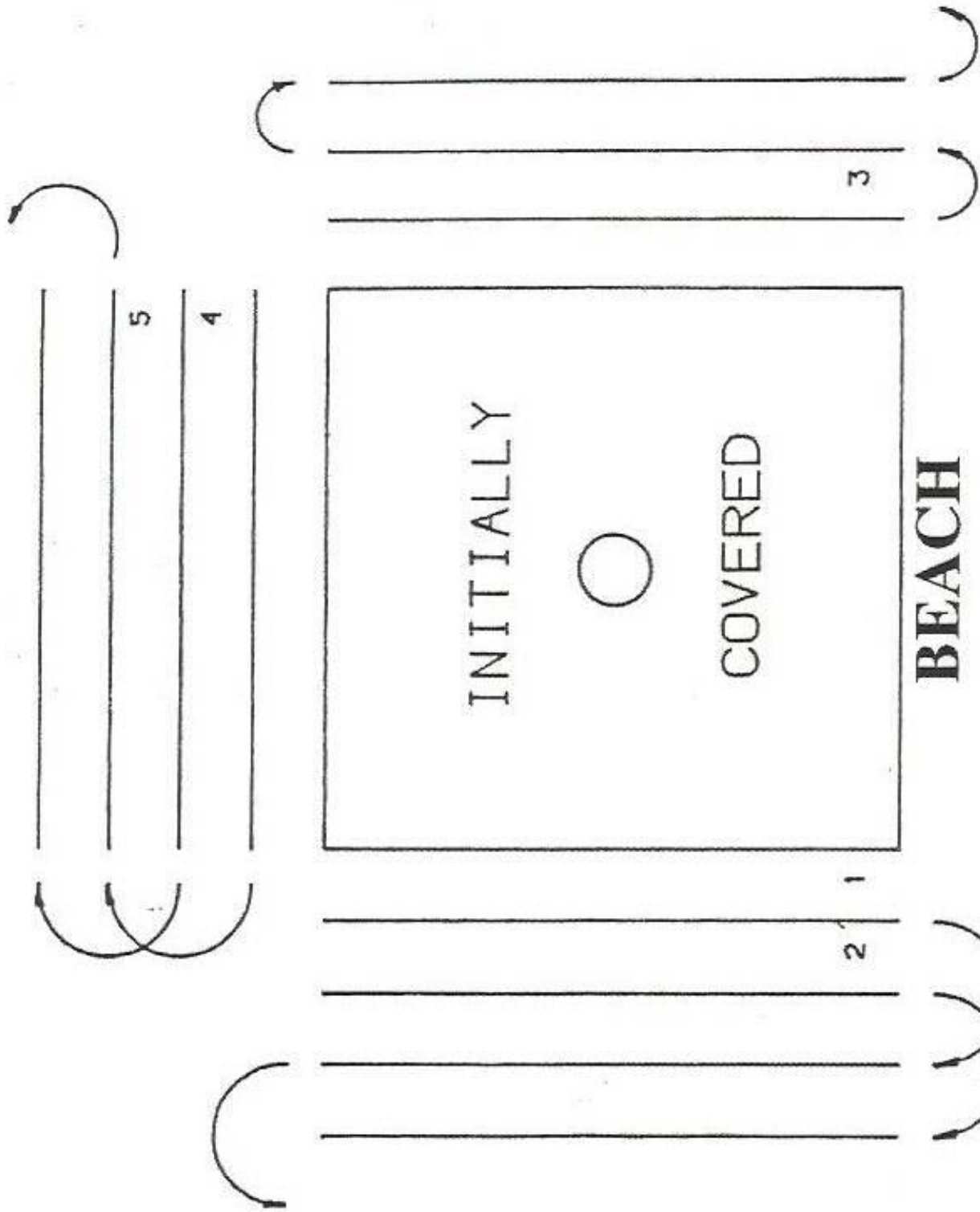

**BEACH**  
 SUBSEQUENT COVERAGE

## VIII. DISTURBANCES

Any fight or similar disturbance should be quelled as quickly as possible. When possible, the State Park Police will be notified and the necessary action left to them. If the State Park Police are not available, a team of at least two lifeguards should investigate the disturbance. If necessary, troublesome patrons should be asked to leave the beach area. Lifeguards will not attempt to detain patrons. A lifeguard's responsibility is the safety of the bathing area, and this should remain the first priority.

## IX. LIGHTNING

### Environmental Hazards

#### Lightning

According to the National Oceanic and Atmospheric Administration there are over 25million lightning strikes a year in the United States. In simple terms, Lightning is described as a “spark” of electricity that occurs when opposite charges in the atmosphere builds up between clouds and/or the ground. Lightning strikes occur at an increased rate during the summer months making lightning a dangerous environmental hazard that should be taken very seriously.

Over 300 hundred people are struck each year and on average, 50 people are killed each year. Many victims are caught off guard or unaware of the risks during a storm and fail to get safely indoors. As a result, precautions should be taken to safe guard both the public and the lifeguard staff when this phenomenon occurs.

As part of the daily routine the following steps should be followed to maximize safety:

1. Prior to coming on duty Lifeguard officers should make note of weather forecasts for the day, specifically noting storm predictions, characteristics and timelines.
2. When storms are predicted, forecasts should be monitored closely throughout the day. Attention should be given to changing weather conditions- changes in cloud formation, darkening skies, changes in wind speed/direction, changes in air temperature and developing precipitation.

(When making the decision to close the beach, lifeguard officers should provide for time required to evacuate the beach safely before the storm hits). Note: it is imperative that Lifeguard officers make every reasonable effort to ensure the safety of the lifeguard staff and public when closing and evacuating the beach.

- a. If thunder is heard, or lightning is seen, the beach should be immediately closed and evacuated.
3. If indications are that a storm is impending, the Superintendent/park office, should be notified that the beach will be closing.
  - a. Utilizing whistle blasts, lifeguards should clear the water of all patrons, equipment should be stored and lifeguard stands placed down on their backs.
  - b. Lifeguards should begin to advise patrons on the beach that “a storm is eminent and the beach is closing, please leave the beach and seek shelter”.

4. Lifeguards should clear and close the beach as quickly and efficiently as possible and seek shelter.
5. Lifeguards will be stationed in sheltered positions to beach access and prevent access.

Following protocols recommended by OSHA, the beach shall remain closed for a minimum of 30- 45 minutes after the last sounds of thunder or observed lightning.

#### X. GUARDING

Maximum service should be provided to the public at all times. A work schedule for lifeguards to maximize protection and use of the swimming area will be made by each area Superintendent in consultation with the regional Water Safety Supervisor.

The only deviation from this schedule will be made when it is raining or water and/or air temperature is below 68 degrees. Any other time the work schedule cannot be carried out, it must be approved by the area Superintendent.

It is the responsibility of the head lifeguard to see that the lifeguard work schedule is carried out.

A. The bathing area is covered by three guarding positions.

1. Stand position
2. Deep water patrol
3. Shallow water patrol

B. It is not reasonable to assume that lifeguards can maintain maximum alertness, hour after hour, at the same position. Regular rotation of guarding positions and relief breaks will minimize boredom and monotony. Coverage of the First Aid Room is considered part of the relief break from the beach and is usually included as part of the rotation system. Each lifeguard should spend at least an hour and a half within the three beach positions and one-half hour or 15 minutes covering the First Aid Room. This rotation system is a minimum guide. Circumstances may require deviations in the rotation system.

### C. Stand Position

The advantages of this position are the ability of the lifeguards to observe bathers from a better vantage point and it allows the patrons to easily observe the lifeguards and their signals.

Duties:

1. Scan the area assigned to the stand.
2. Give directions to shallow water patrol and deep-water patrol concerning rule breakers and unsafe situations.
3. Correct rule breakers and prevent unsafe situations when shallow water patrol or deep-water patrol is not readily available.
4. Scan adjacent areas frequently.
5. Lifeguards on stands are not to get into prolonged conversations with patrons. If a patron has a question or problem that requires more than a short answer, direct them to someone who has time to talk to them. When you answer a patron's inquiry do not look at them. Continue to scan your area.
6. Take a torpedo buoy with you anytime you must leave the stand position for coverage, assist, rescue or to give instructions to patron. The torpedo buoy must be taken so the guard is ready for a rescue and can be identified.

### D. Deep Water Patrol

Utilizes the kayak and/or rescue board and patrols the water just beyond the bathers. The advantages of this position are speed in the water and the ability to observe bathers from a different angle. The kayak or rescue board is considered a most important point of observation and contact with the bathers. Deepwater patrol should be used daily to achieve maximum protection (P-50).



### P-50

Duties:

1. Scans from waist deep water to the deepest end of the bathing area - keeps poor swimmers in waist deep water.

- 
2. Maintains a position that allows all bathers in deep water to be observed and from which a rescue can be made quickly and easily without endangering patrons.

3. Correct rule breakers and prevent unsafe situations.
4. Scan beach and shallow water frequently.
5. Watch for boats approaching the bathing area.
6. Patrons are not to be on the kayak or hanging on the kayak, unless they are having swimming difficulties.
7. Guards should carry out a swift and efficient rotation of this position to provide maximum protection of bathers.

#### E. Shallow Water Patrol

The advantage of this position is mobility that allows the guard to quickly respond to problems. This position is especially effective when there is a large group of small children concentrated in one area.

##### Duties:

1. Scan shallow water up to chest height.
2. Scan deep water frequently.
3. Assist stand lifeguard in answering patrons' questions and/or in handling other problems.
4. Correct rule breakers and prevent unsafe situations.
5. Face the water and continue to scan if you must answer a patron's inquiry.
6. Assist lost children.
7. Perform minor or immediate first aid. Patrons who are able, should be directed to the First Aid Room when it is staffed.
8. Carry a torpedo buoy to be prepared for a rescue and to be easily identified by both the patrons and other guards.
9. Identify unattended children and locate parents.

#### F. Scanning

Scanning is the method used for watching the bathers. Starting at one end of the area, work across to the other end, looking at each bather for a brief moment, making note of anyone who could possibly have trouble in the next few moments. On the next sweep across the area, re-evaluate each bather previously noted, and take note of other bathers that now have given an indication that they may become a problem. While scanning, overlap your area with adjacent area and keep an eye on adjacent lifeguard stands. When a lifeguard is relieved or moved to another position, he must inform his replacement of the bathers that he has noted during the past few minutes who may become a problem.

1. A few things to watch for while scanning:
  - a. Poor Swimmer.
  - b. Swimmers becoming tired or weak.
  - c. Unattended children.
  - d. People pulling themselves along the buoy lines instead of swimming.
  - e. Rule violators.
  - f. Unnatural or excessive splashing with arms.
  - g. Poor swimmers going out over their heads.
  - h. People in the water with street clothes on.
  - i. Those possibly under the influence of alcohol or drugs.
2. While scanning, an alert lifeguard will recognize a patron with poor swimming ability heading towards trouble, other actions dangerous to his/her welfare, or rule violations. The lifeguard sighting an unsafe situation or rule breakers should stand up, get the patron's attention with one whistle blast, and warn the patron to prevent serious problems.
3. A guard must recognize a red and white divers flag, if displayed, and ascertain through the chain-of-command if a diving permit has been issued by the area office. If in a lifeguard craft, stay 50 feet from the flag. A diver holding one hand over head means a diver needs assistance.

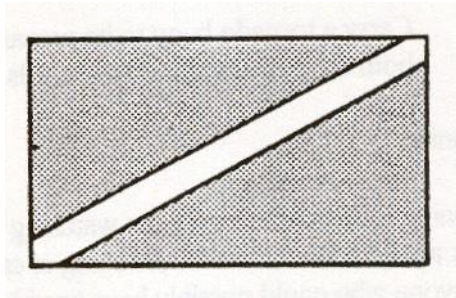

**Red and White  
Divers Flag**

4. A bather with one hand raised above his/her head is requesting assistance. This sign is the universal symbol for help in the water.



# GUARDS SCANNING THE BATHING AREA.

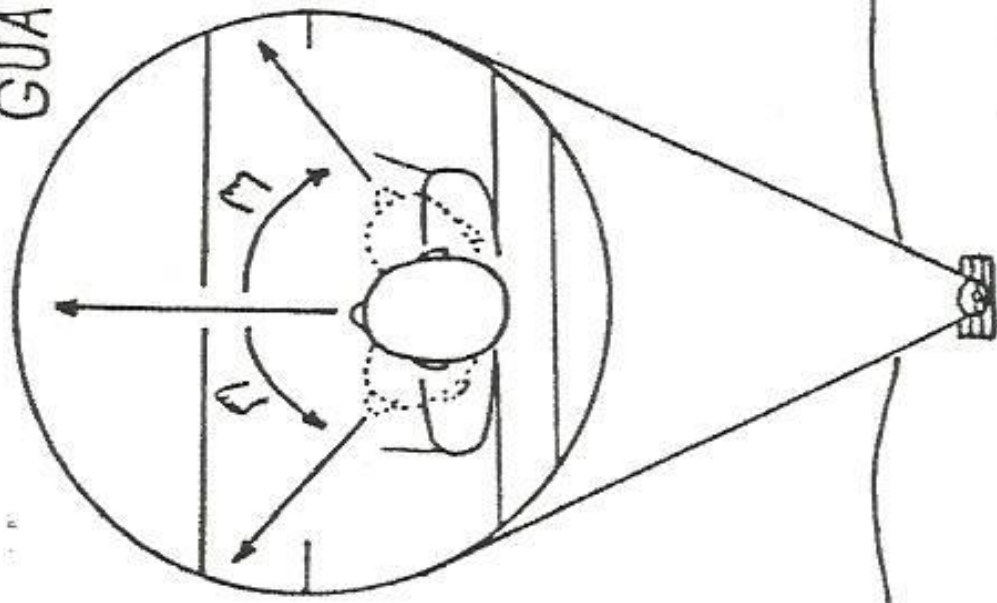

KAYAK

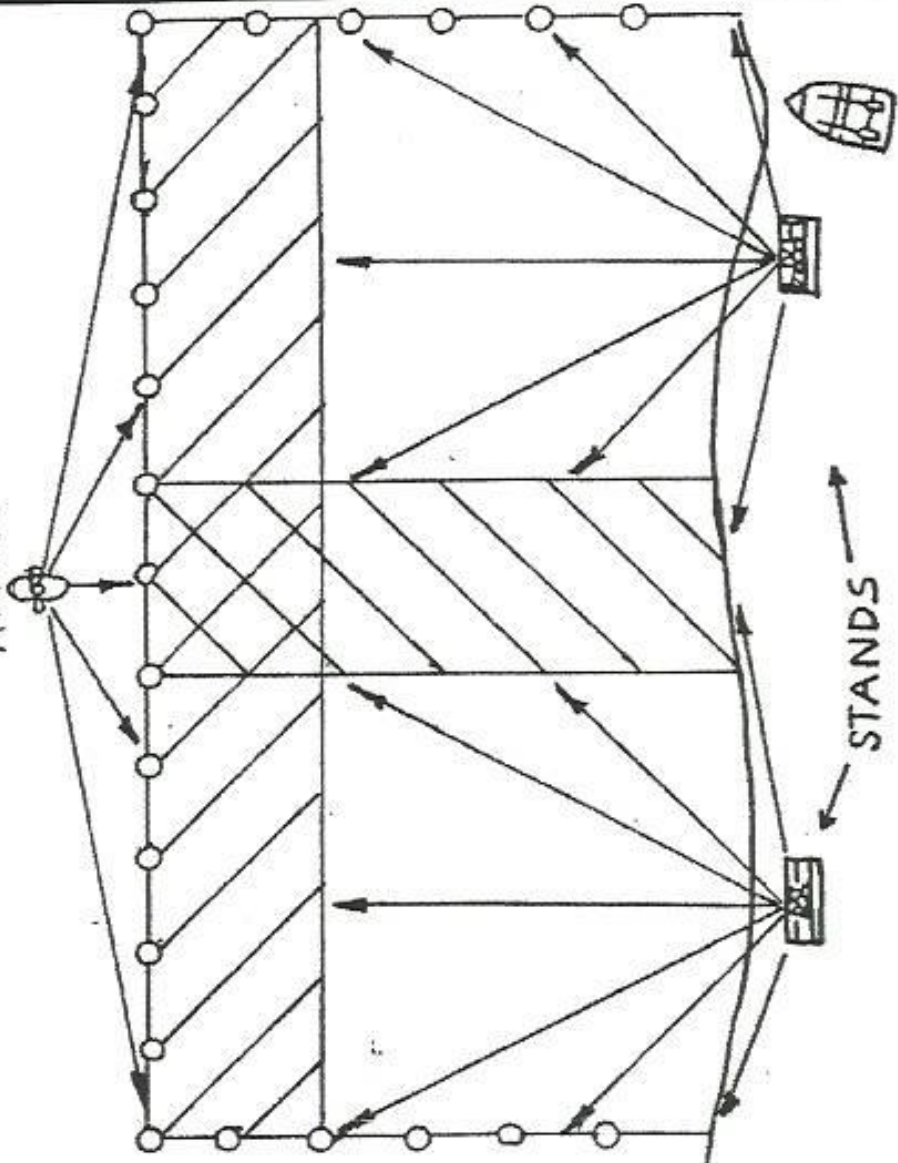

COVERAGE WHERE ADJACENT STANDS OVERLAP

COVERAGE WHERE STANDS AND KAYAK OVERLAP



BEACH

STANDS

## XI. RESCUE PROCEDURE AND COVERAGE

Any guard going on a rescue or assist should blow three or more short rapid whistle blasts and respond with a torp or kayak.

Rescue Coverage - The following procedures are to ensure that no areas are left unguarded during a rescue.

- A. When a lifeguard on a stand goes for a rescue, the lifeguards on adjacent stands, stand up and blow rescue whistles if not already done by rescuer while pointing in the direction of the rescue. The lifeguard must continue to scan his or her own area and also scan the area where the lifeguard went on rescue. This lifeguard may assist, depending on the circumstances.

The second lifeguard on the scene will assist and should be from one of the following positions:

1. Shallow water patrol.
2. Nearest available lifeguard (on break).
3. A lifeguard from an adjacent two person stand.
4. A lifeguard from deep water patrol.
5. A lifeguard from an adjacent one person stand.

The guards who assist are listed above in order of preference. This means a shallow water patrol guard is preferred to a guard from a one person stand that would be left empty. Who can assist a rescue most efficiently will be dictated by staff and how the beach is set up at the time.

Which guard (1-5 above) is in the best position to assist in different situations should be thoroughly discussed and understood by all lifeguards at each area.

The stand vacated by the lifeguard should be occupied by the third lifeguard on the scene. This guard will scan the other bathers and not just watch the rescue. If more help is needed on the original rescue, this guard should assist.

The third lifeguard on the scene comes from one of the following positions (listed in order of preference):

1. The nearest guard on shallow water patrol.
2. The nearest available guard.
3. One guard from an adjacent 2-person stand.
4. A lifeguard on deepwater patrol.
5. A lifeguard from an adjacent one person stand.

The guard above (1-5) who is to fill an empty stand in different situations should be thoroughly discussed and understood by all lifeguards at each area.

ALL RESCUE PROCEDURES AND COVERAGES WILL BE PRACTICED BY ALL LIFEGUARDS DURING IN-SERVICE TRAINING.

B. Lifeguards not participating in the rescue must be sure to scan the bathing area extra care fully at these times because:

1. THERE IS A DECREASE IN THE NUMBER OF LIFEGUARDS WATCHING THE BATHERS.
2. EVERYONE'S ATTENTION IS ON THE RESCUE AND PEOPLE MAY TEND TO FORGET ABOUT THE CHILDREN OR POORER SWIMMERS THEY ARE WITH.
3. THE POSSIBILITY EXISTS THAT A BATHER IN ANOTHER PART OF THE BATHING AREA MAY PANIC DURING THE RESCUE.

C. If a rescue or beach emergency requires all lifeguards to leave the lifeguard stand with no backup coverage the bathing area must be first cleared of all bathers.

## XII. REMOVING VICTIMS FROM SHALLOW WATER TO THE BEACH

1. Assisting an exhausted conscious victim to shore (P-51).

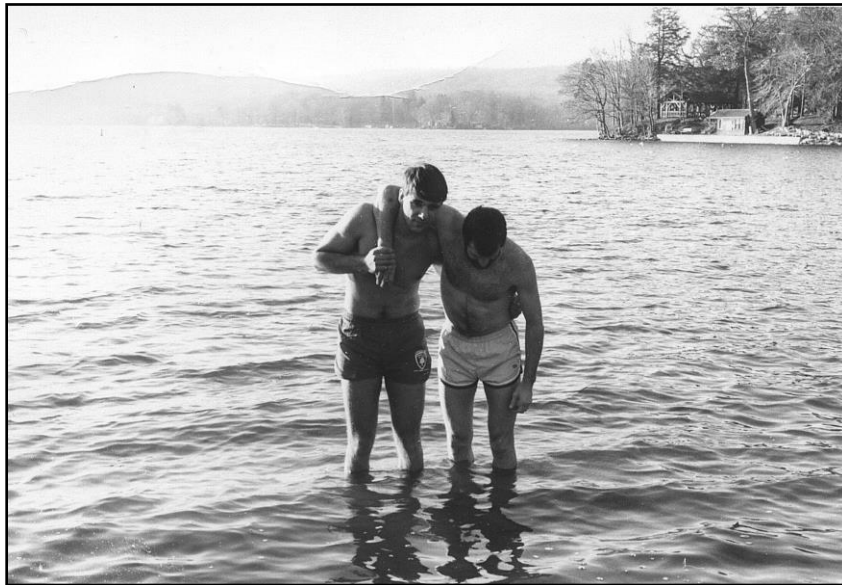

**P-51**

2. Chair carry used by 2 lifeguards to bring a victim to shore (P-52, P-53).



**P-52**

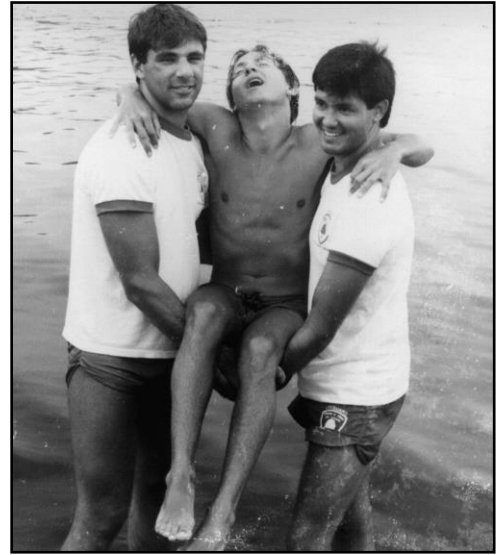

**P-53**

3. A victim is dragged to shore if it is necessary for one lifeguard to remove an unconscious victim from the water, however, the chair carry is preferred (P-54).



**P-54**

4. **AN AMBULANCE WILL BE CALLED FOR ANY VICTIM WHO HAS LOST CONSCIOUSNESS AT ANY TIME DURING A RESCUE OR HAS TAKEN IN WATER. (NEAR DROWNING)**

### XIII. RESCUES WITHOUT LIFESAVING EQUIPMENT

The USLA and the American Red Cross do not recommend rescues without equipment when lifesaving equipment is available. A State Park Service lifeguard should attempt a water rescue with available equipment. However, a guard is to learn the following skills in case a guard gets caught in a rescue situation without equipment or the equipment taken for the rescue malfunctions.

- A. Non-equipment rescue skills
  - 1. Approaches
    - a. Rear (Swim and Dive)
    - b. Front surface
    - c. Submerged victim
  - 2. Level Offs
    - a. Single armpit
    - b. Double armpit
  - 3. Carries and tows
    - a. Cross chest
    - b. Control cross chest
    - c. Single and double armpit tows
    - d. Armpit assist for tired swimmers with one or two lifeguards
    - e. Wrist tow
  - 4. Defenses
    - a. Block and re-approach victim
  - 5. Releases and Escapes
    - a. Front head hold
    - b. Rear head hold
    - c. Double drowning release
    - d. Wrist grip

These skills will be taught and tested according to the methods discussed in chapter 9, page 137 of the American Red Cross Lifeguarding Textbook. When learning or reviewing these skills, the Lifeguarding Textbook must be consulted.



New Jersey Department of Environmental Protection  
Division of Parks and Forestry  
State Park Service  
PO Box 420  
Mail Code 501-04  
Trenton, NJ 0862509420



I certify that I have read and understand the New Jersey State Park Service Lifeguard Manual for State Operated Lake Beaches dated May 2021.

**Name:** \_\_\_\_\_

**Signature:** \_\_\_\_\_

**Date:** \_\_\_\_\_

**SPS Area:** \_\_\_\_\_